

GREEN ARCHITECTS' LOUNGE

presents

Sprout Follies

www.GreenBuildingAdvisor.com





CHRISTOPHER BRILEY, RA, LEED BD+C
BRIBURN
28 MAPLE ST. PORTLAND, MAINE
207-774-8482 www.architectureforlife.com
cbriley@briburn.com

PHIL KAPLAN, AIA, LEED AP
KAPLAN THOMPSON ARCHITECTS
424 FORE ST. PORTLAND, MAINE
207-842-8888 www.kaplanthompson.com
phil@kaplanthompson.com

YOU MAY BE NEW AT THIS.





Everybody.



...and I mean, everybody.



...seriously, everybody.



HOME

ABOUT US

SERVICES

GALLERY

GREEN

CONTACT US



DESIGN EXCELLENCE

Lorem ipsum dolor sit amet, consectetur adipiscing elit. Etiam neque nisi, interdum ac porta non, condimentum eu tellus. Nunc rhoncus sem quis metus cursus sagittis....



PELLENESQUE A EST FELIS
MODERN



MORBI SIT AMET TELLUS
COMMERCIAL



FUSCE NULLA NISL
RESIDENTIAL



“Our houses breathe
naturally”

“We’re green
experts. We use the
LEEDS system”

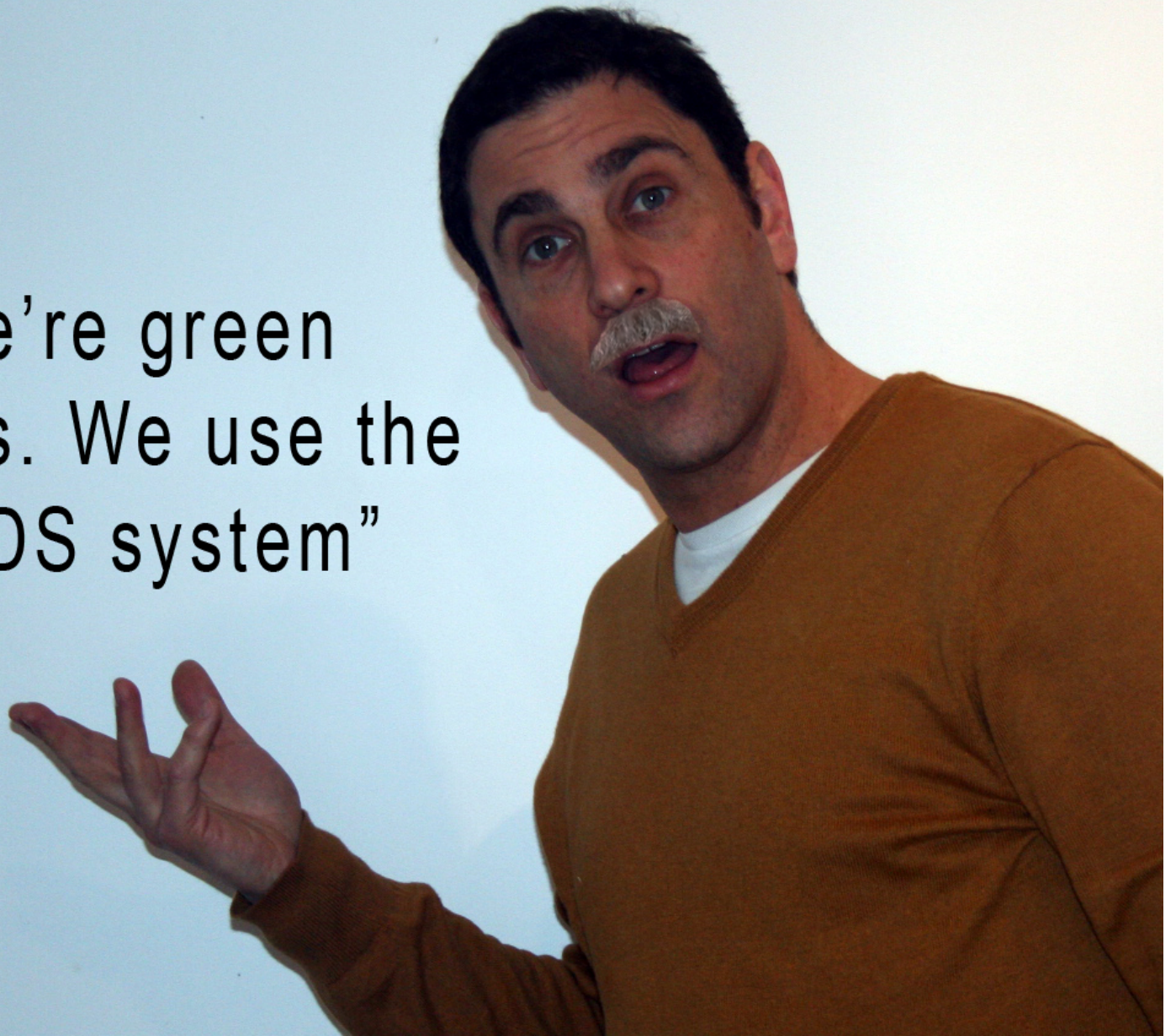



“We use efficient systems like geothermal, and radiant slabs”

“We use SIP panels
for our walls and
roofs, and spray
foam for those
tricky spots”





“We use the highest quality low-e windows, like Marvin and Pella”

“We advocate for solar panels for all of our houses.”



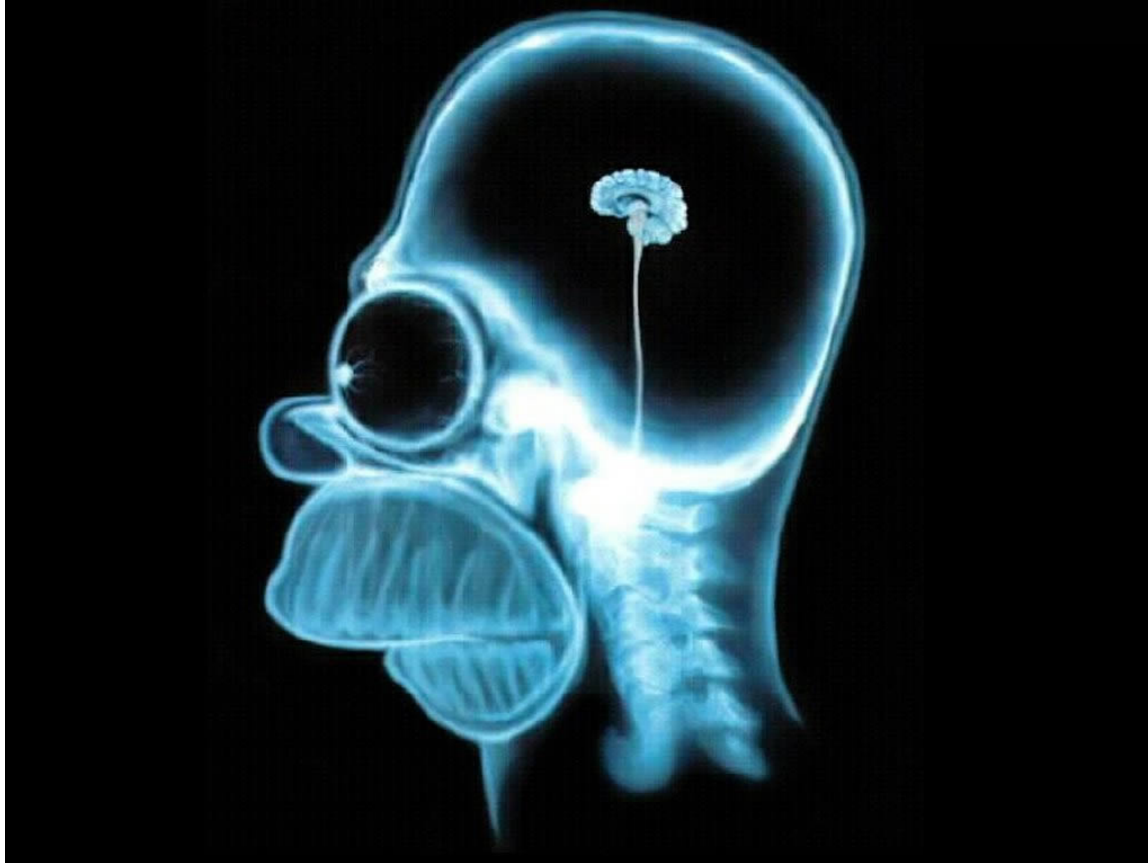

**FIX THE “MOUTH TO BRAIN” RATIO.
SEEK KNOWLEDGE, SEEK ADVICE, EXERCISE THAT
BRAIN!**

**15 TOP TEN
THINGS NOT TO
BLOW**

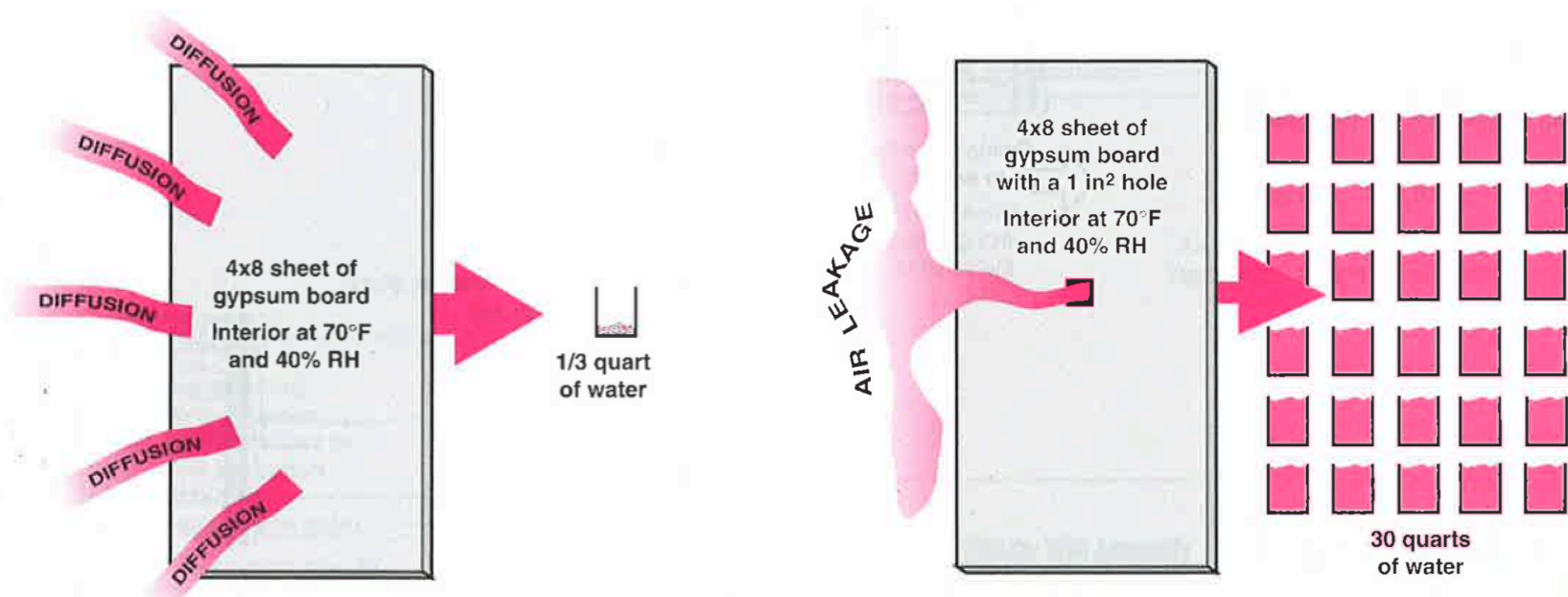

1. Don't be an Airhole!



ROOF AND WALL SI

LA-M
SIGA W/IN

7
0
1
7

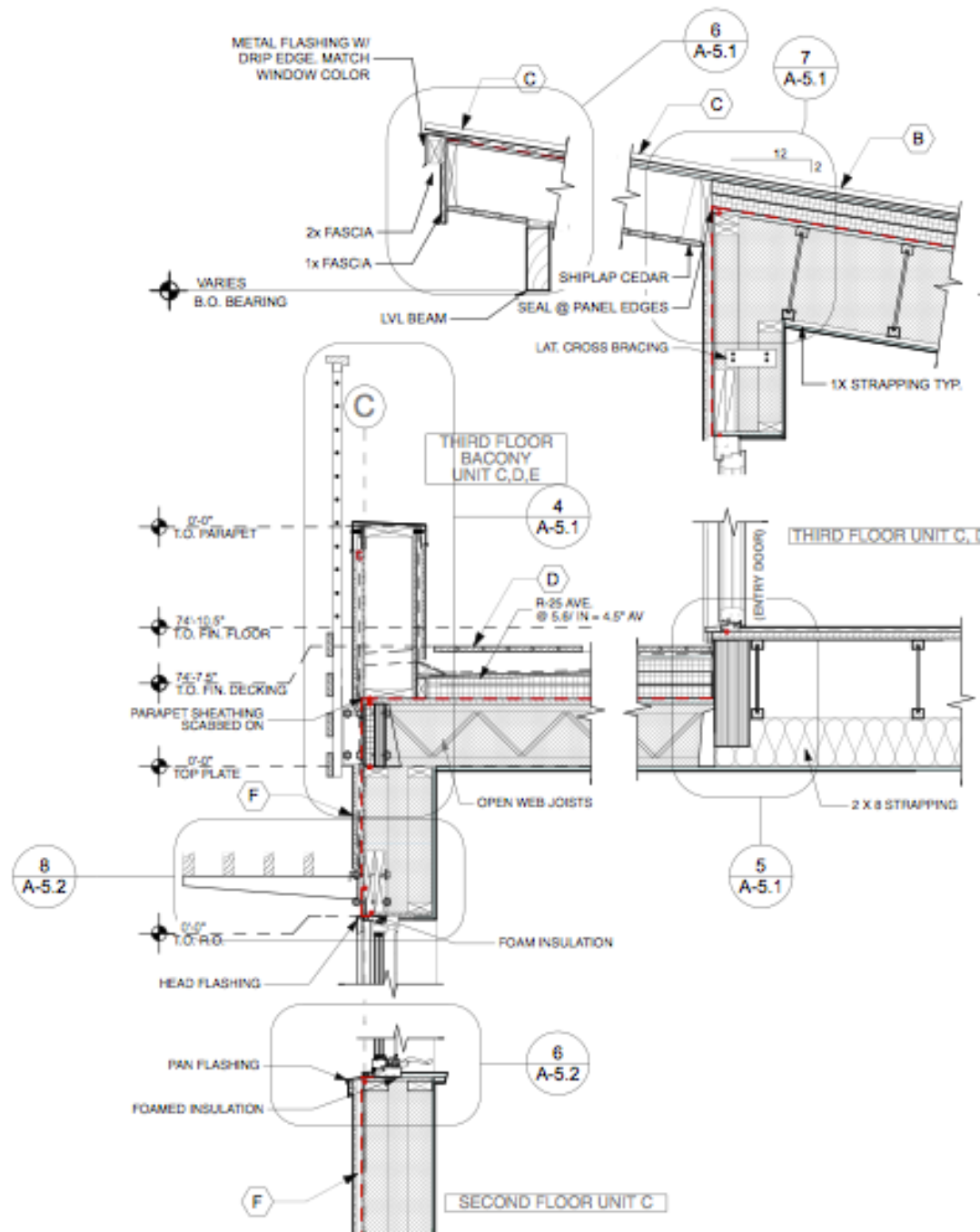

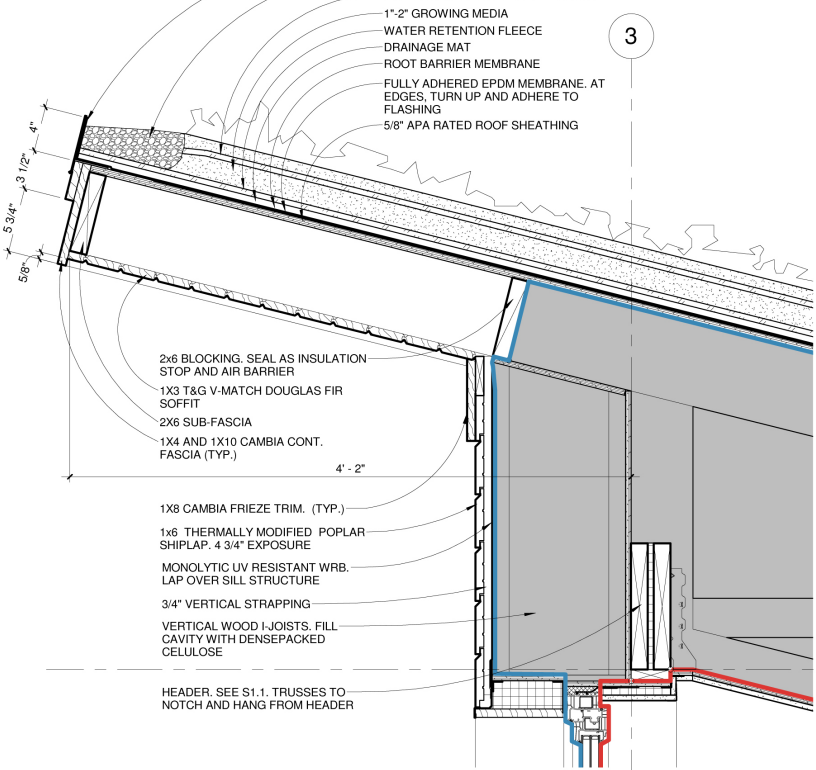

- 1"-2" GROWING MEDIA
- WATER RETENTION FLEECE
- DRAINAGE MAT
- ROOT BARRIER MEMBRANE
- FULLY ADHERED EPDM MEMBRANE. AT EDGES, TURN UP AND ADHERE TO FLASHING
- 5/8" APA RATED ROOF SHEATHING

1 ROOF PEAK DETAIL
1 1/2" = 1'-0"

T.O. WALL S. LIVING ROOM
117' - 3"

- VAPOR INFILTRATION BARRIER
- AIR INFILTRATION BARRIER

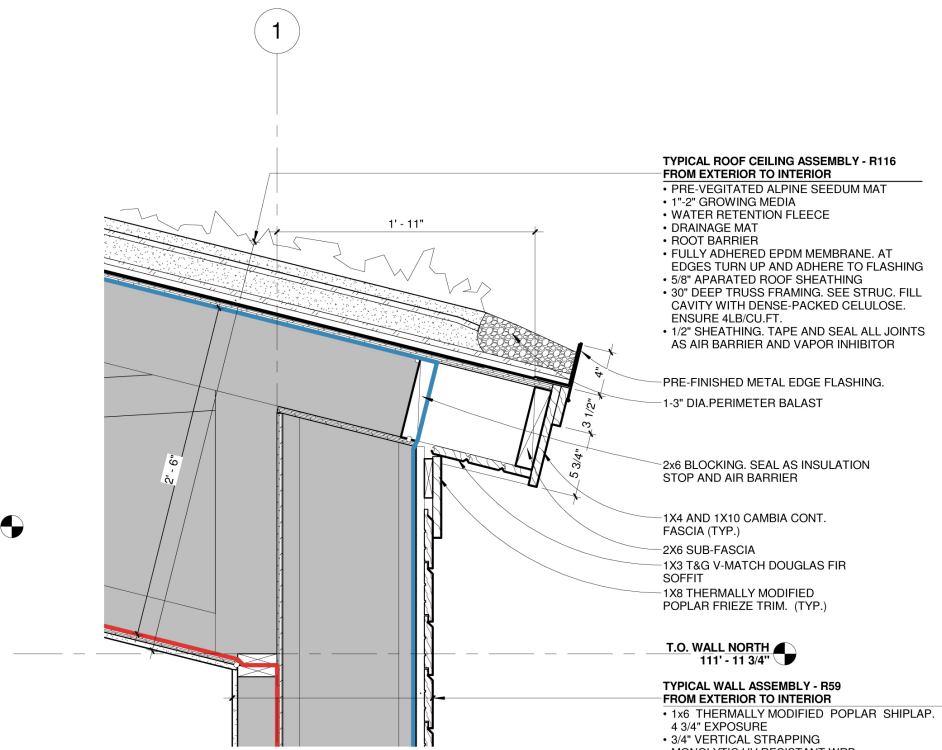

- TYPICAL ROOF CEILING ASSEMBLY - R116 FROM EXTERIOR TO INTERIOR**
- PRE-VEGETATED ALPINE SEEDUM MAT
 - 1"-2" GROWING MEDIA
 - WATER RETENTION FLEECE
 - DRAINAGE MAT
 - ROOT BARRIER
 - FULLY ADHERED EPDM MEMBRANE. AT EDGES TURN UP AND ADHERE TO FLASHING
 - 5/8" APARATED ROOF SHEATHING
 - 30" DEEP TRUSS FRAMING. SEE STRUC. FILL CAVITY WITH DENSE-PACKED CELLULOSE. ENSURE 4LB/CU.FT.
 - 1/2" SHEATHING. TAPE AND SEAL ALL JOINTS AS AIR BARRIER AND VAPOR INHIBITOR

- PRE-FINISHED METAL EDGE FLASHING.
- 1-3" DIA. PERIMETER BALAST
- 2x6 BLOCKING. SEAL AS INSULATION STOP AND AIR BARRIER

- 1x4 AND 1x10 CAMBIA CONT. FASCIA (TYP.)
- 2x6 SUB-FASCIA
- 1x3 T&G V-MATCH DOUGLAS FIR SOFFIT
- 1x8 THERMALLY MODIFIED POPLAR FRIEZE TRIM. (TYP.)

T.O. WALL NORTH
111' - 11 3/4"

- TYPICAL WALL ASSEMBLY - R59 FROM EXTERIOR TO INTERIOR**
- 1x6 THERMALLY MODIFIED POPLAR SHIPLAP. 4 3/4" EXPOSURE
 - 3/4" VERTICAL STRAPPING
 - MONOLYTIC UV RESISTANT WRB.
 - VERTICAL WOOD I-JOISTS. ALIGN W/ AND FASTEN TROUGH TO STUDS W/ 4" GRK RSS SCREWS (OR APPROVED EQUAL). FILL CAVITY WITH DENSEPACKED CELLULOSE.
 - 1/2" APA RATED WALL SHEATHING. TAPE AND SEAL ALL JOINTS AS AIR BARRIER AND VAPOR INHIBITOR
 - 2x4 STUD WALL (24" O.C.)
 - 1/2" GWB

2 ROOF EAVE DETAIL
1 1/2" = 1'-0"

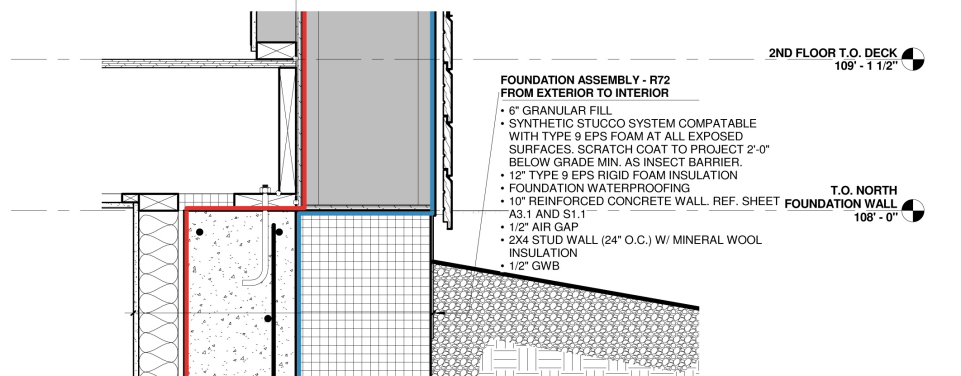

- FOUNDATION ASSEMBLY - R72 FROM EXTERIOR TO INTERIOR**
- 6" GRANULAR FILL
 - SYNTHETIC STUCCO SYSTEM COMPATABLE WITH TYPE 9 EPS FOAM AT ALL EXPOSED SURFACES. SCRATCH COAT TO PROJECT 2'-0" BELOW GRADE MIN. AS INSECT BARRIER.
 - 12" TYPE 9 EPS RIGID FOAM INSULATION
 - FOUNDATION WATERPROOFING
 - 10" REINFORCED CONCRETE WALL. REF. SHEET A3.1 AND S1.1
 - 1/2" AIR GAP
 - 2x4 STUD WALL (24" O.C.) W/ MINERAL WOOL INSULATION
 - 1/2" GWB

2ND FLOOR T.O. DECK
109' - 1 1/2"

T.O. NORTH FOUNDATION WALL
108' - 0"



2. Raise your glass



	BIEBER PASSIVA	SCHMELLA TRIPPLE PANE	SCHMANDERSEN 400	
U-FACTOR- GLASS	0.106	0.171	0.30	(Btu/hr · ft ² F°)
U-FACTOR- FRAME	0.13	0.35	?	(Btu/hr · ft ² F°)
SHGC	0.62	0.55	0.48	
VT	0.73	0.69	0.54	



LoE 180

HIGH SOLAR GAIN GLASS

This advertisement features a shield-shaped logo with a yellow and black gradient. The number '180' is prominently displayed in a large, metallic font, with 'LoE' to its left and a small 'by AGC' to its right. Below the number is a stylized window icon. The background of the shield is a dark, curved shape. The overall design is set against a background of a bright sun and trees.



LoE 366

ULTIMATE PERFORMANCE
GLASS FOR ALL CLIMATES

This advertisement features a shield-shaped logo with a yellow and black gradient. The number '366' is prominently displayed in a large, metallic font, with 'LoE' to its left and a small 'by AGC' to its right. Below the number is a stylized window icon. The background of the shield is a dark, curved shape. The overall design is set against a background of a person's face.



LoE 272

ADVANCED PERFORMANCE
GLASS FOR MOST
CLIMATES

This advertisement features a shield-shaped logo with a yellow and black gradient. The number '272' is prominently displayed in a large, metallic font, with 'LoE' to its left and a small 'by AGC' to its right. Below the number is a stylized window icon. The background of the shield is a dark, curved shape. The overall design is set against a background of trees and a blue sky.



LoE 181

ENHANCED
PERFORMANCE GLASS

This advertisement features a shield-shaped logo with a silver and black gradient. The number '181' is prominently displayed in a large, metallic font, with 'LoE' to its left and a small 'by AGC' to its right. Below the number is a stylized window icon. The background of the shield is a dark, curved shape. The overall design is set against a background of trees and a blue sky.





**3. Don't cross that bridge
when you come to it**





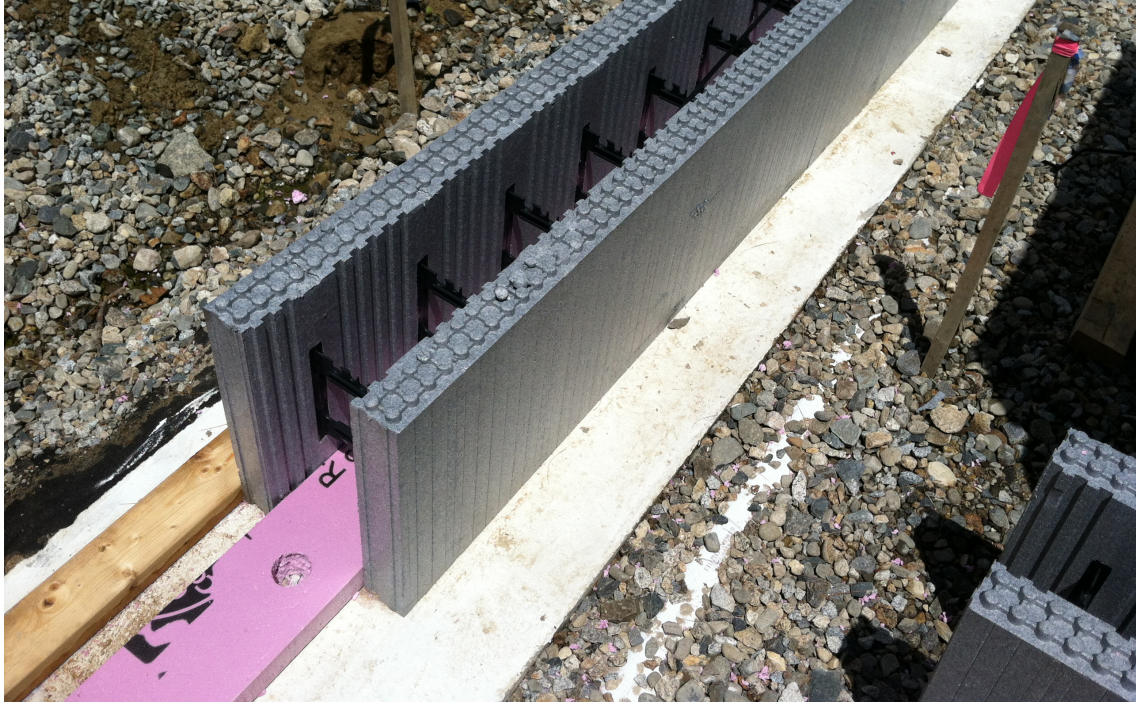

3

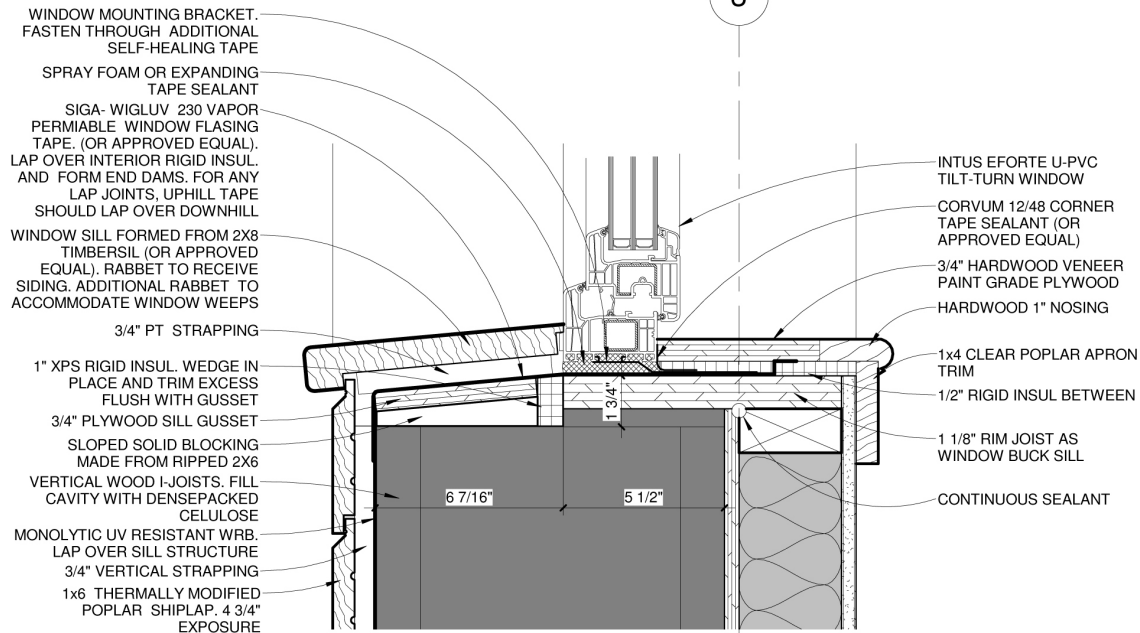

1 TYPICAL WINDOW SILL DETAIL
3" = 1'-0"

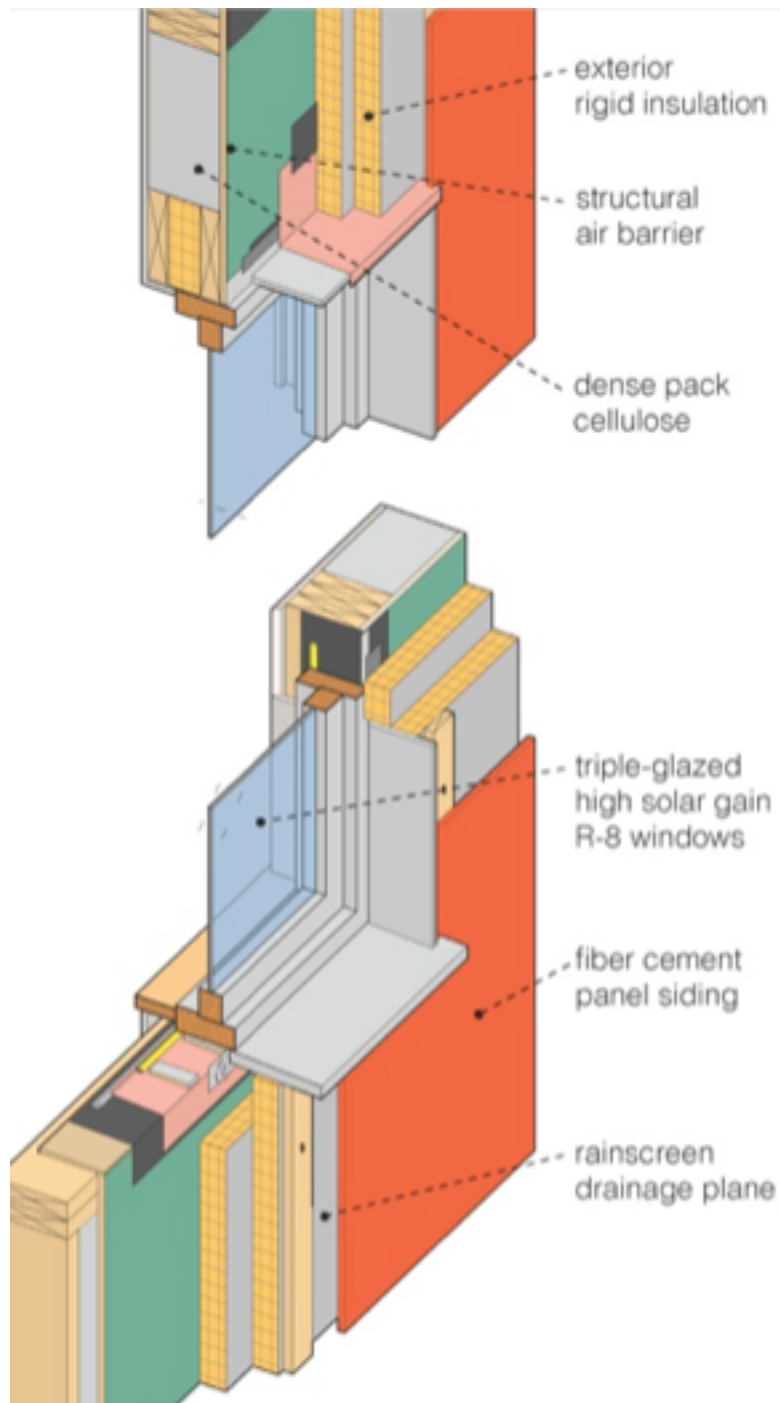



4. Belt, suspenders and clean underwear (a.k.a. redundancy and redundancy)



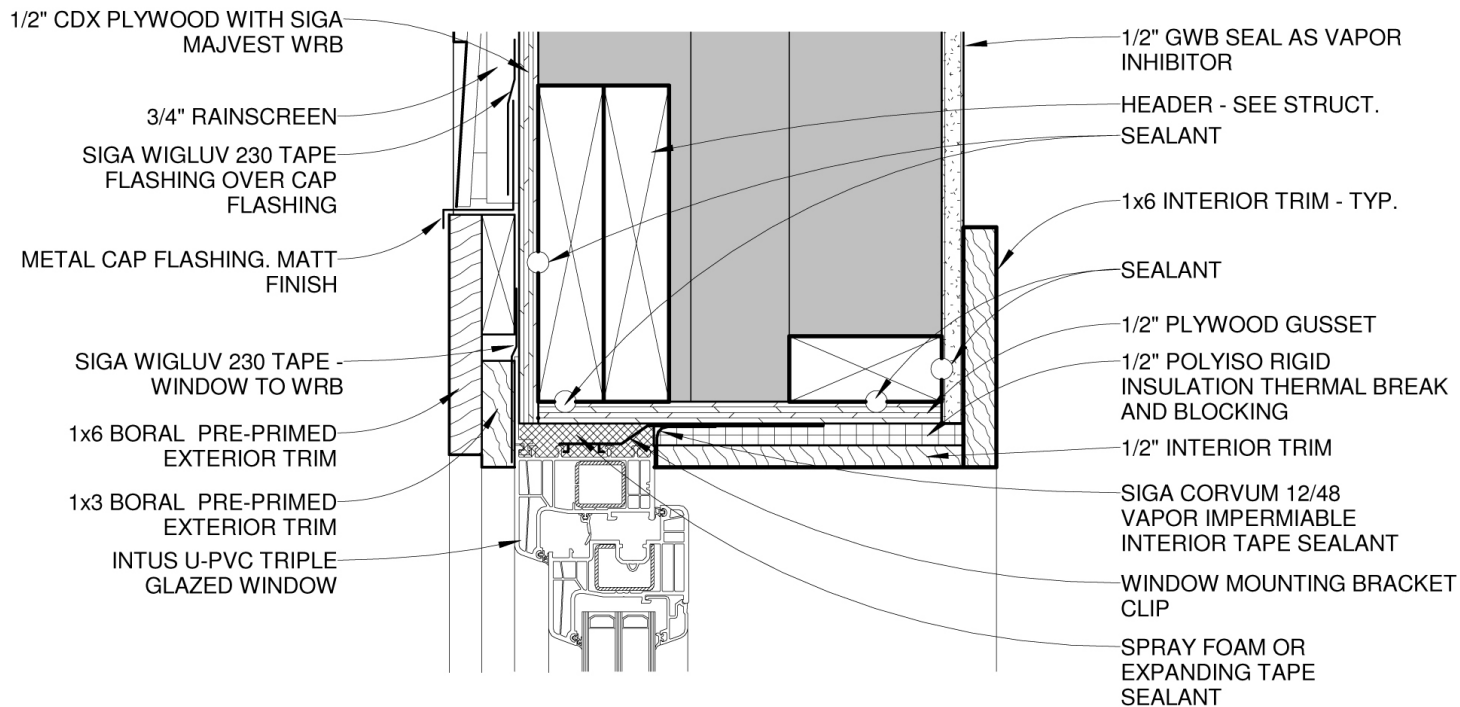

1 MGBS WINDOW HEAD DETAIL
 3" = 1'-0"

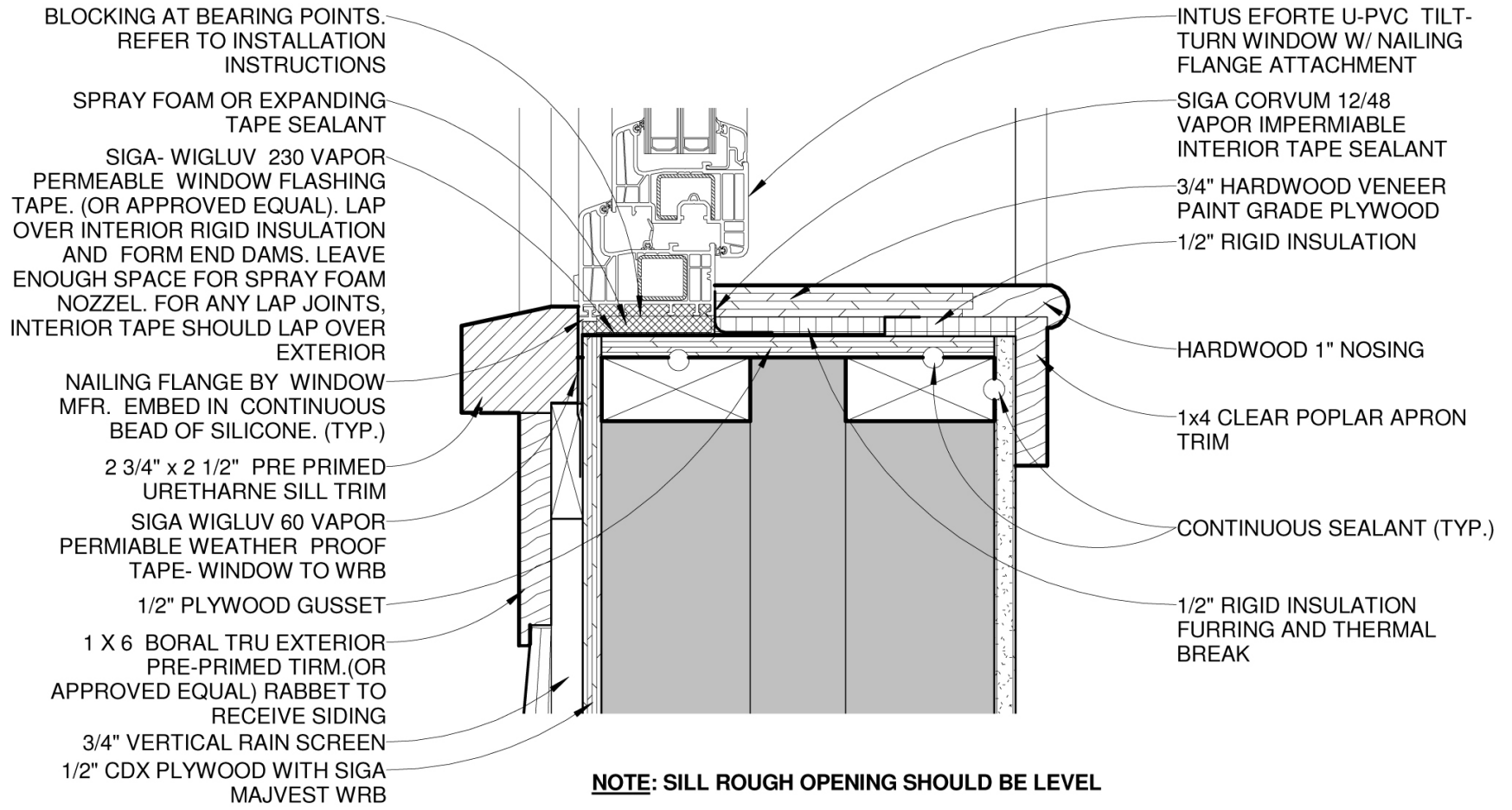

1 MGBS WINDOW SILL DETAIL
 3" = 1'-0"









5. Group hug!

(a.k.a. Don't wait to integrate)

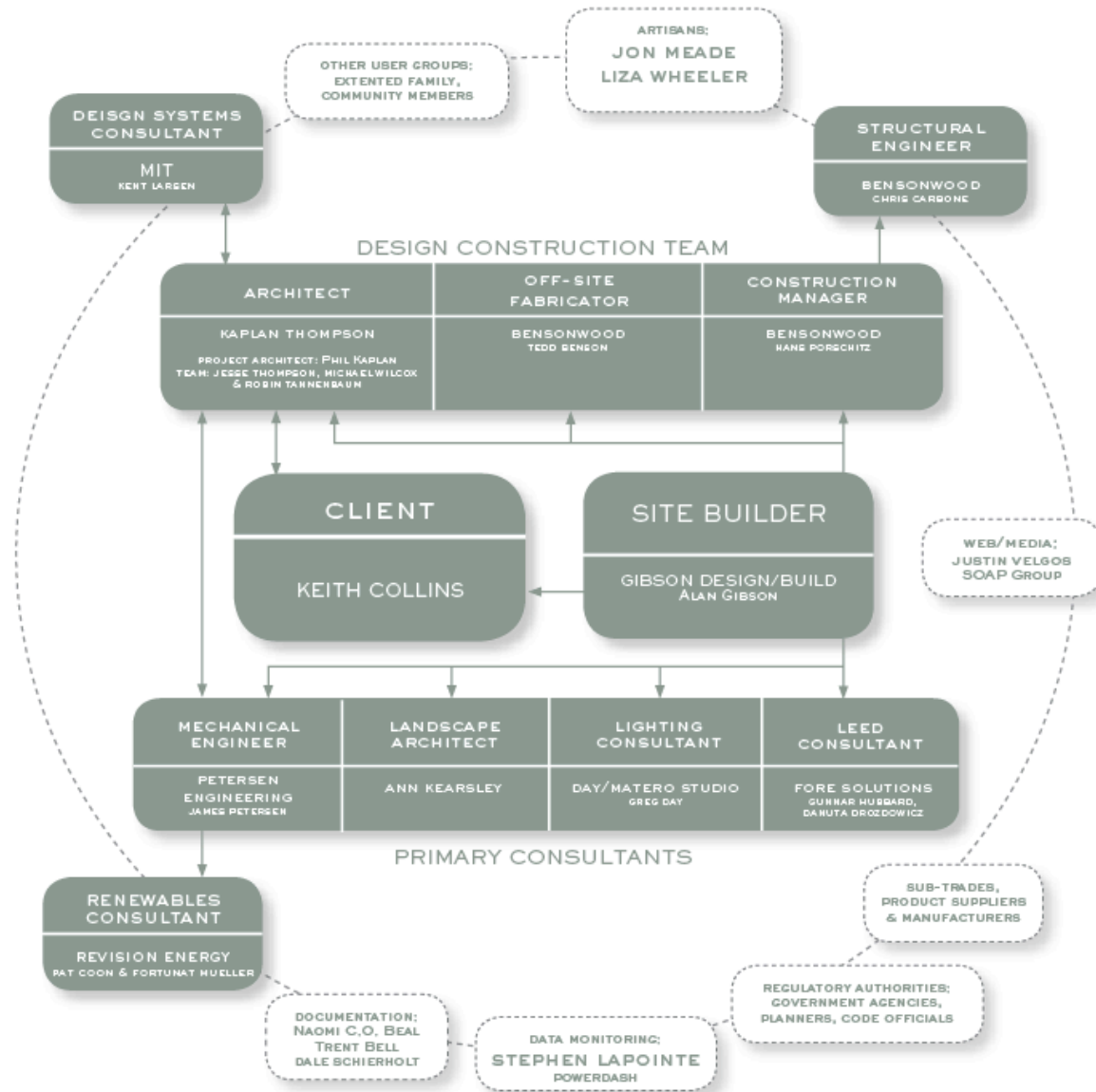

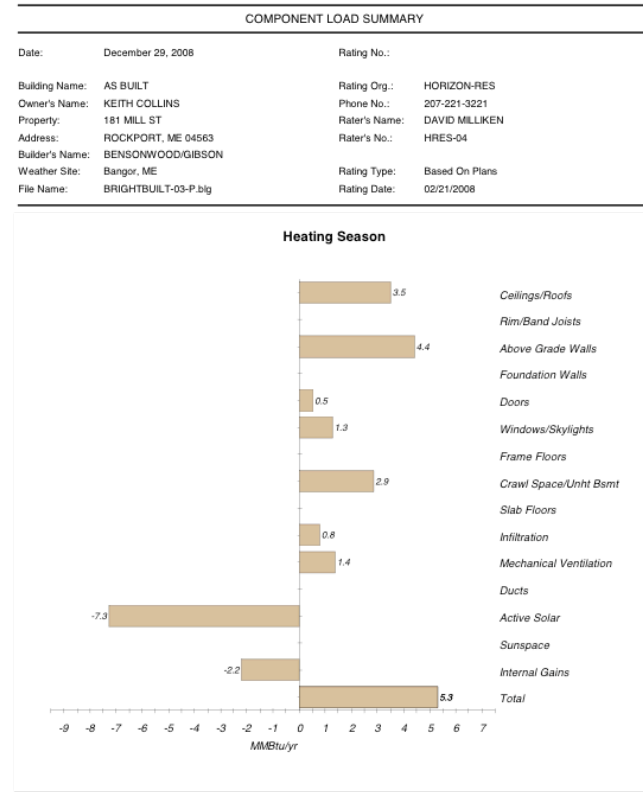

REMRate - Residential Energy Analysis and Rating Software v12.6
 This information does not constitute any warranty of energy cost or savings.
 © 1985-2008 Architectural Energy Corporation, Boulder, Colorado.

6. Do your modeling before the runway

Passive House Verification

Photo or Drawing

Building: **Normand Residence**

Location and Climate: **PHI/NASA Saco Maine**

Street: **18 Edgewater Lane**

Postcode/City: **Saco, Maine**

Country:

Building Type:

Home Owner(s) / Client(s): **Roger & Lynn Normand**

Street: **18 Edgewater Lane**

Postcode/City: **Saco, Maine**

Architect: **Green Design Studio**

Street:

Postcode/City:

Mechanical System:

Street:

Postcode/City:

Year of Construction: **2012**

Number of Dwelling Units: **1**

Enclosed Volume V_e: **1622.0** m³

Number of Occupants: **3.3**

Interior Temperature: **20.0** °C

Internal Heat Gains: **2.1** W/m²

no standard climate

Calculation Electricity / Internal Heat Gains

Building Type: Residential Building

Internal Heat Gains

Utilization Pattern: Residential building

Type of Value Used: Standard

Planned Number of Occupants:

7

Verification

Verification:

Monthly method

Specific Space Heating Demand, Annual Method	15.4
Specific Space Heating Demand, Monthly Method	14.7

Specific Demands with Reference to the Treated Floor Area

Treated Floor Area: **326.9** m²

	Applied:	Monthly method	PH Certificate:	Fulfilled?
Specific Space Heating Demand:	15	kWh/(m² a)	15 kWh/(m² a)	Yes
Heating Load:	12	W/m²	10 W/m²	Yes
Pressurization Test Result:	0.6	h⁻¹	0.6 h⁻¹	Yes
Specific Primary Energy Demand (DHW, Heating, Cooling, Auxiliary and Household Electricity):	76	kWh/(m² a)	120 kWh/(m² a)	Yes
Specific Primary Energy Demand (DHW, Heating and Auxiliary Electricity):	30	kWh/(m² a)		
Specific Primary Energy Reduction through Solar Electricity:		kWh/(m² a)		
Frequency of Overheating:		%	over 25 °C	
Specific Useful Cooling Energy Demand:	3	kWh/(m² a)	15 kWh/(m² a)	Yes
Cooling Load:	6	W/m²		

We confirm that the values given herein have been determined following the PHPP methodology and based on the characteristic values of the building. The calculations with PHPP are attached to this application.

Issued on:

signed:

BUILDING ELEMENTS

VENTILATION

EXHAUST ONLY
x HRV OR ERV **83%** % EFFICIENT

AIR TIGHTNESS

0.60 ACH50:

R- VALUES

52	WALLS	TYPE: Wall: Double Stud 12"
101	ROOF	TYPE: Roof: TRUSS w cellulose
0	SUSPENDED FLOORS	TYPE:
0	BASEMENT WALLS	TYPE:
36	SLABS	TYPE: Slab on Grade, 4" XPS

WINDOWS & DOORS

WINDOWS

	SHGC:	0.56
GLASS 7.69	U-VALUE:	0.13
FRAME 6.69	U-VALUE:	0.15
TOTAL 5.87	U-VALUE:	0.17

SOLID DOORS

9.00 U-VALUE: **0.11**

GLAZED DOORS

GLASS	SHGC:	0.56
GLASS 7.69	U-VALUE:	0.13
FRAME 6.69	U-VALUE:	0.15
TOTAL 5.87	U-VALUE:	0.17

GLAZING % OF TFA

12% SOUTH:
 5% NORTH:
 2% EAST:
 2% WEST:

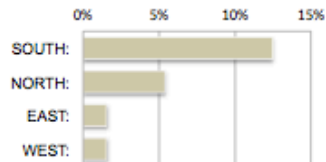

PEAK LOAD **21,120** BTU / HOUR (EQUIP SIZING)
PEAK LOAD PER UNIT PRIMARY ENERGY **2,347** kBTU / SF / YEAR (TOTAL DAMAGE)
31.24 kBTU / SF / YEAR (TOTAL DAMAGE)

SITE ENERGY **4.56** kBTU / SF / YEAR (LOCAL DAMAGE)
PV TO BE NET-ZERO **19.42** KW
 PV PANELS NEEDED **84** 1,055 SF OF PV

ANNUAL HEATING **4.73** kBTU / SF / YEAR (TOTAL HEATING)
ANNUAL COOLING kBTU / SF / YEAR (TOTAL COOLING)

WINDOW ENERGY **488** KBTU / YEAR (ENERGY + OR -)

HEAT GAINS

SOLAR GAINS: **33%**
 PEOPLE, LIGHTS & APPLIANCES: **30%**
 MECHANICAL HEATING: **37%**

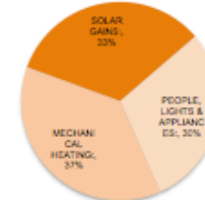

HEAT LOSS

BUILDING SHELL: **44%**
 WINDOWS: **29%**
 VENTILATION & AIR LEAKS: **27%**

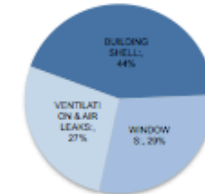

SHELL LOSSES

WALLS: **62%**
 ROOF: **14%**
 BASEMENT WALLS & SLAB: **24%**

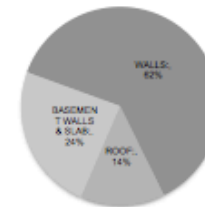

SCHEME A: PASSIVHAUS

**Thomaston Sail
Lofts**

TFA: **5,670**
 US SF: **6,480**

CLIMATE LOCATION:
THOMASTON, ME

Wesolowski Residence

Summary of energy model and system options:
29-Aug-12

	1. Ductless min-split system	2. Ductless mini-split w/ Propane DHW	3. Ductless mini-split w/ HP DHW	4. Ductless mini-split w/ HP DHW. And PV Solar	5. Ductless mini-split w/ HP DHW. And PV Solar And Solar Hot Water	6. Ductless mini-split. And Solar Hot Water
	(2) Mitsubishi Hyper Heat Ductless Split Heat Pumps. COP= 2.5-3.0. .94 EF. Marathon HW tank	(2) Mitsubishi Hyper Heat Ductless Split Heat Pumps. COP= 2.5-3.0. - Rinnai Continuum Propane thru-wall	(2) Mitsubishi Hyper Heat Ductless Split Heat Pumps. COP= 2.5-3.0. - 2.4 EF. Voltex Heat Pump, 60 gal.	(2) Mitsubishi Hyper Heat Ductless Split Heat Pumps. COP= 2.5-3.0. - 2.4 EF. Voltex Heat Pump, 60 gal. - 2.88 KW Solar system	(2) Mitsubishi Hyper Heat Ductless Split Heat Pumps. COP= 2.5-3.0. - 2.4 EF. Voltex Heat Pump, 60 gal. - 2.88 KW Solar system - (2) Wagner Solar HW Flat Plate Collectors	(2) Mitsubishi Hyper Heat Ductless Split Heat Pumps. COP= 2.5-3.0. - 2.4 EF. Voltex Heat Pump, 60 gal. - 2.88 KW Solar system - (2) Wagner Solar HW Flat Plate Collectors
Demand:						
Component Load - Heating (MMBtu/yr.)	19.4	19.4	19.4	19.4	19.4	19.4
Component Load - Hot Water (MMBtu/yr.)	14.6	14.6	14.6	14.6	14.6	14.6
Design Day Load Heating (kBtu/hr)	15.2	15.2	15.2	15.2	15.2	15.2
Design Day Load Cooling (kBtu/hr)	109	109	109	109	109	109
Consumption						
Component Consumption Heating (MMBtu/yr.)	11.6	11.6	11.6	11.6	11.6	11.6
Component Consumption - Hot Water (MMBtu/yr.)	14.9	14.9	14.9	14.9	14.9	14.9
Heating Consumption (kWh)	3,139	3,139	3,139	3,139	3,139	3,139
Cooling Consumption (kWh)	673	673	673	673	673	673
Domestic Hot Water Consumption (kWh)	4,360	0	1,668	1,668	0	0
Domestic Hot Water Consumption (gal)		163				
Lighting & Appliances (kWh)	5,896	5,896	5,896	5,896	5,896	5,896
Capacity of Heat system BTU/hr	18,000	18,000	18,000	18,000	18,000	18,000
Estimated Renewable (MMBtu/yr)	0	0	0	0	12.6	12.6
Estimated Renewable (Kw/hr)	0	0	0	3,839	3,839	3,839
Estimated HERS Rating (lower is better) Standard ASHREA house =100 Energy Star = 80	43	35	36	?	?	?
Combustion Free	YES	NO	YES	YES	YES	YES
Annual Operating Cost						
Total Estimated Annual Energy Cost for Heating, DHW, L&A: Propane @ 3.25/gal and Elec. @ \$0.15/kwh	\$ 2,009	\$ 1,926	\$ 1,605	\$ 1,030	\$ 779	\$ 1,355
Total Estimated Annual Energy Cost for Cooling: Propane @ 3.25/gal and Elec. @ \$0.15/kwh	\$ 101	\$ 101	\$ 101	\$ 101	\$ 101	\$ 101
System Installation Cost						
Heat Sorce System:	\$ 9,446	\$ 9,446	\$ 9,446	\$ 9,446	\$ 9,446	\$ 9,446
Hot Water system	\$ 1,200	\$ 2,600	\$ 2,350	\$ 2,350		
Distribution	\$ -	\$ -	\$ -	\$ -	\$ -	\$ -
ERV	\$ 3,200	\$ 3,200	\$ 3,200	\$ 3,200	\$ 3,200	\$ 3,200
Supplemental (towel warmers)	\$ 1,100	\$ 1,100	\$ 1,100	\$ 1,100	\$ 1,100	\$ 1,100
Solar PV	\$ -	\$ -	\$ -	\$ 10,931	\$ 10,931	
Solar DHW	\$ -	\$ -	\$ -	\$ -	\$ 10,565	\$ 10,565
Total:	\$ 14,946	\$ 16,346	\$ 16,096	\$ 27,027	\$ 35,242	\$ 24,311
Tax Credits Rebates available						
30% Fed Tax Credit for Solar	\$ -	\$ -	\$ -	\$ 3,279	\$ 6,449	\$ 3,170
Additional 25% Efficiency Maine	\$ -	\$ -	\$ -	\$ 1,913	\$ 2,000	\$ 1,849
Total Savings	\$ -	\$ -	\$ -	\$ 5,192	\$ 8,449	\$ 5,018
Total net cost of system:	\$ 14,946	\$ 16,346	\$ 16,096	\$ 21,835	\$ 26,793	\$ 19,293

Wesolowski - Solar PV and Solar Hot Water Comparison

12 Panel Solar PV and Voltex Heat Pump Hot Water Heater						
	Heating - kWh	Cooling - kWh	Hot Water - kWh	Lights and Appliances - kWh **	PV Solar Offset - kWh	Total
Annual Load / Demand	3396	440	1668	5896	-3839	7561
Annual Cost at \$0.135 / kWh*	\$458.46	\$59.40	\$225.18	\$795.96	-\$518.27	\$1,020.74

12 Panel Solar PV and Solar Hot Water System						
	Heating - kWh	Cooling - kWh	Hot Water - kWh	Lights and Appliances - kWh **	PV Solar Offset - kWh	Total
Annual Load / Demand	3396	440	703	5896	-3839	6596
Annual Cost at \$0.135 / kWh*	\$458.46	\$59.40	\$94.91	\$795.96	-\$518.27	\$890.46

Additional PV pannels	3	<--Add panels to see affect on installation cost and annual savings
Additional install cost	\$1,914	<--

12 Panel Solar PV and Voltex Heat Pump Hot Water Heater						
	Heating - kWh	Cooling - kWh	Hot Water - kWh	Lights and Appliances - kWh **	PV Solar Offset - kWh	Total
Annual Load / Demand	3396	440	1668	5896	-4784	6616
Annual Cost at \$0.135 / kWh*	\$458.46	\$59.40	\$225.18	\$795.96	-\$645.84	\$893.16

* Estimated cost in Freeport, Maine

** Rem Rate's estimate based on house size

kWH vs. kW
heat pump COP
U-value & SHGC
achNAT vs ach50
kBTU/sf/year



7. Bigger isn't better

(a.k.a. Toe-dipping will leave you all wet)

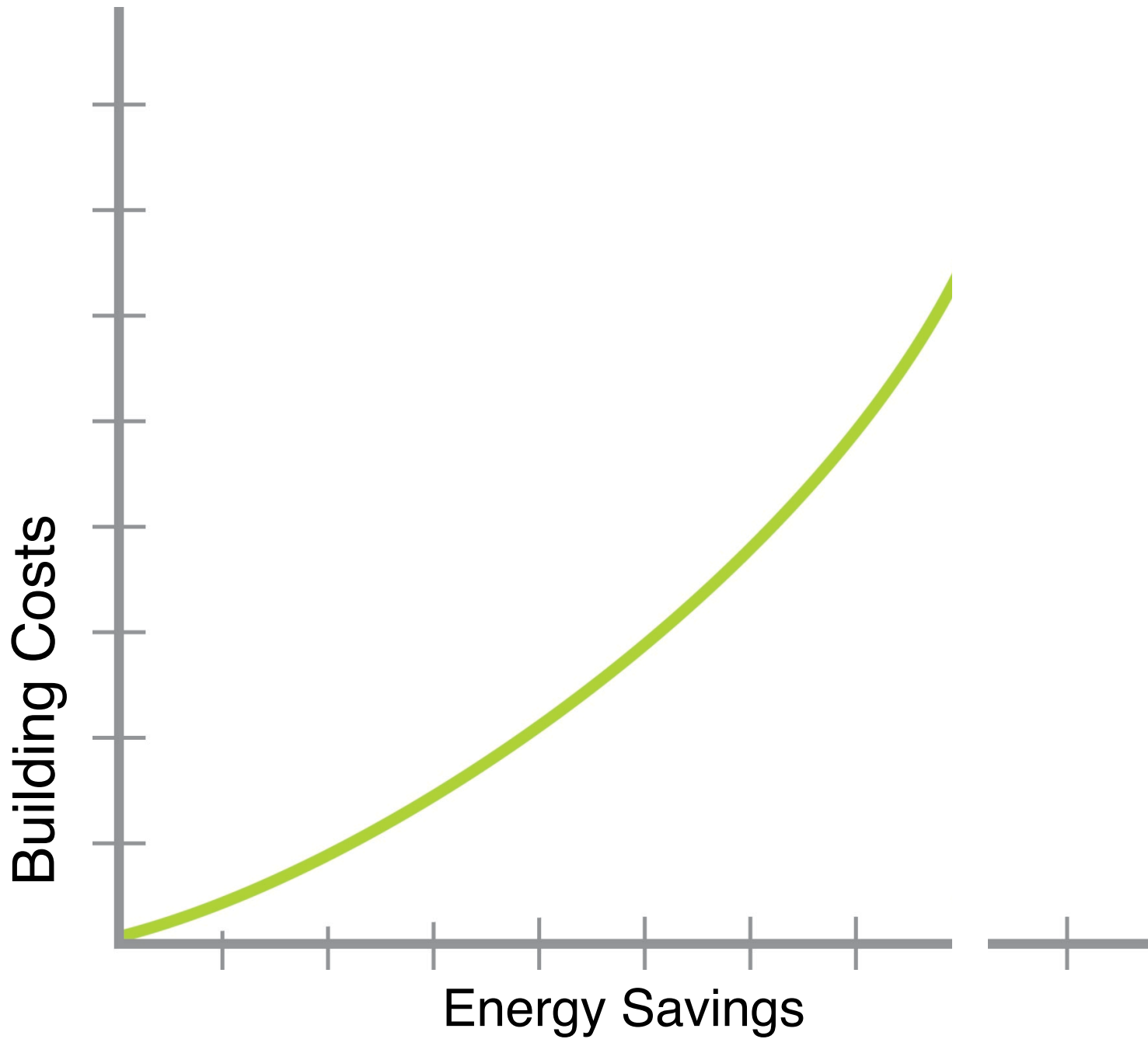

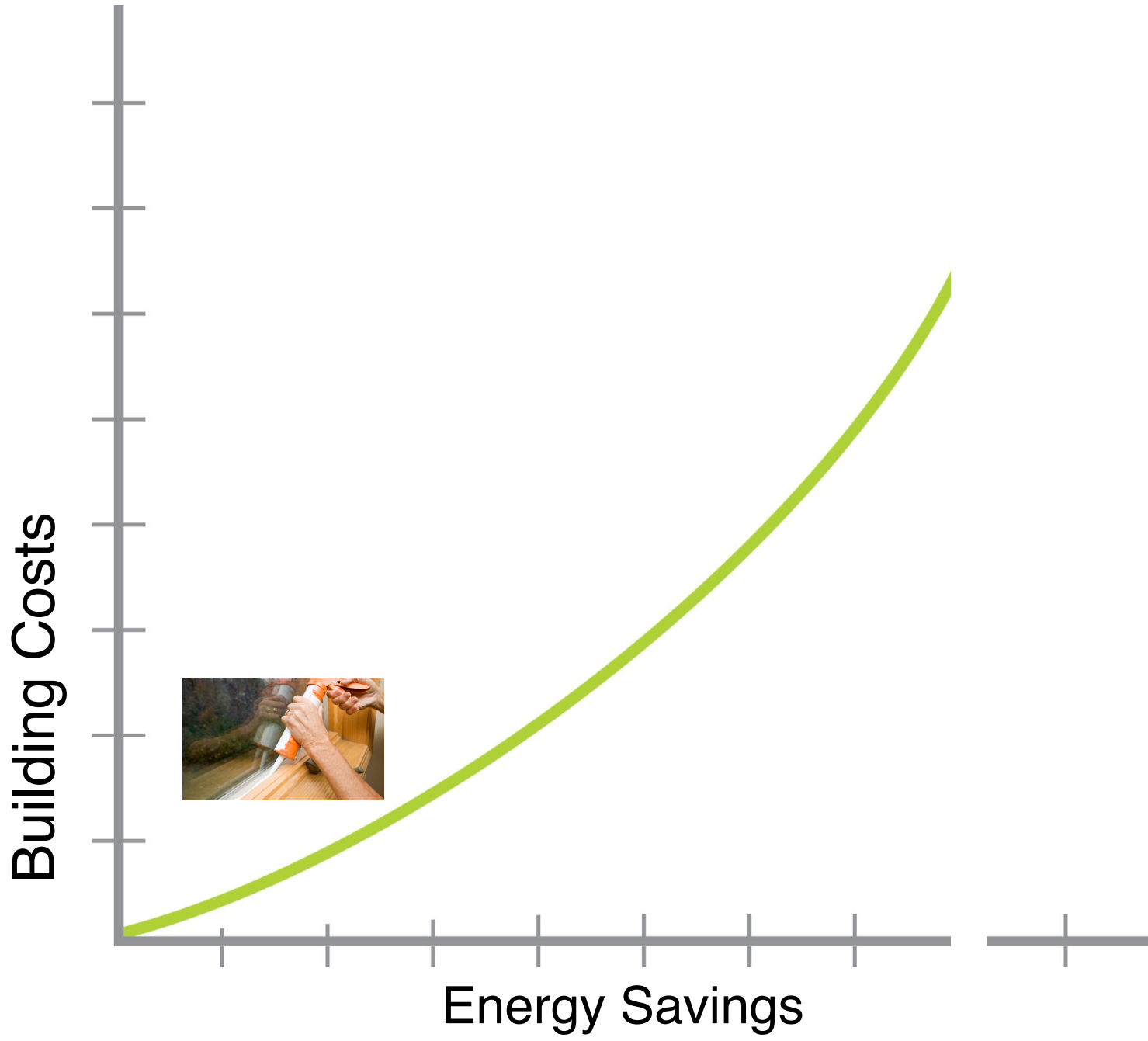

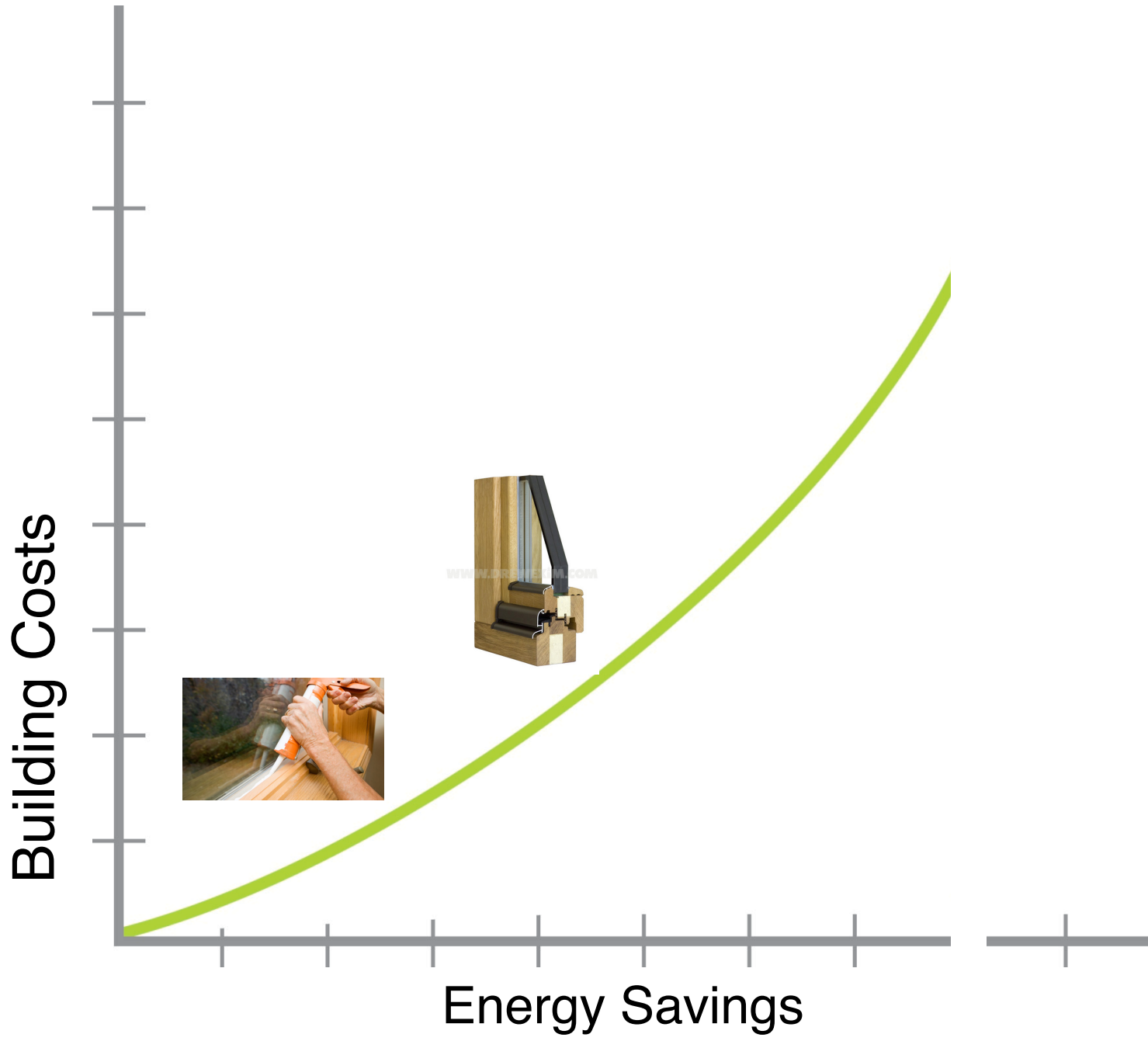

Building Costs

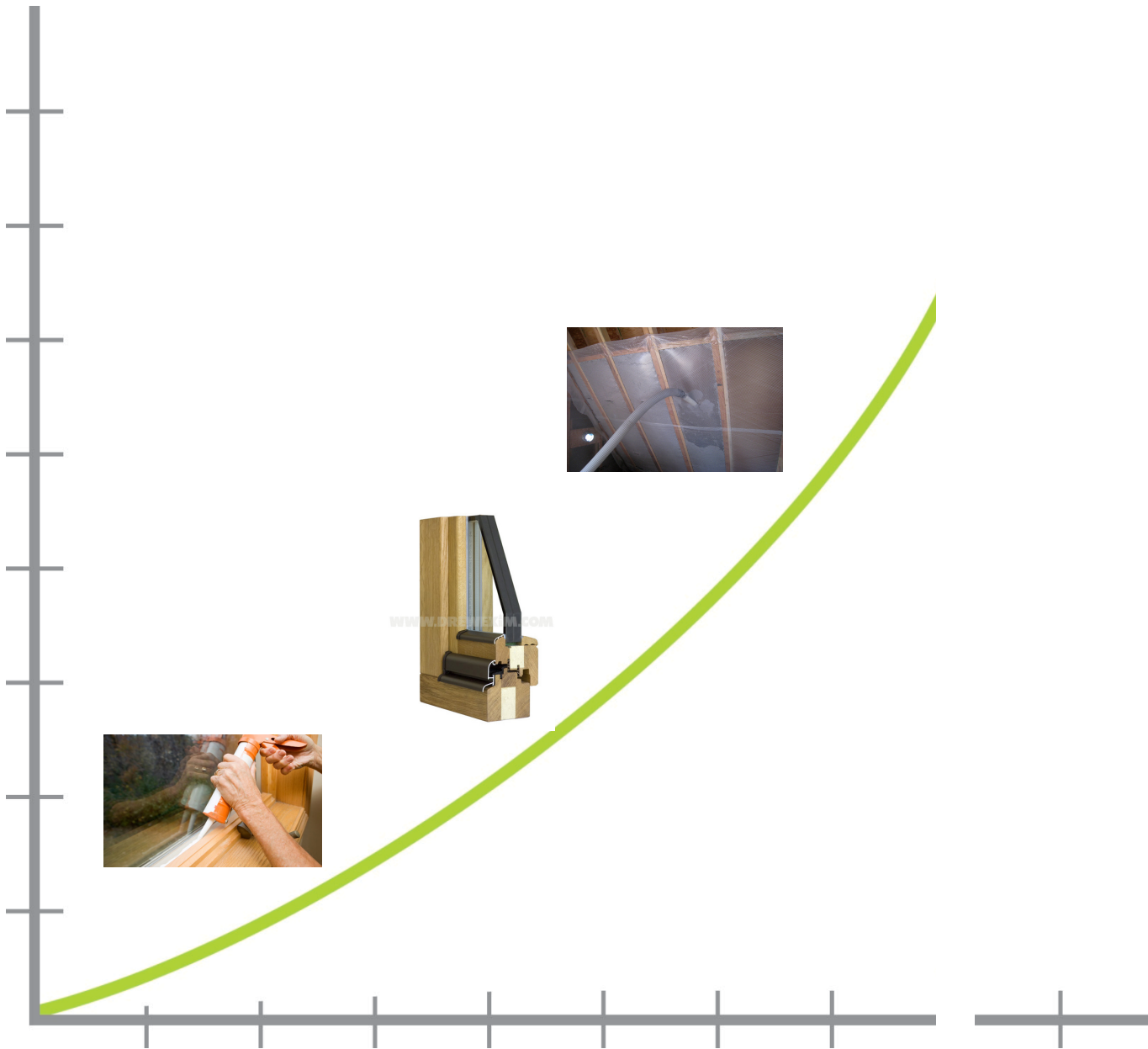

Energy Savings

Building Costs

Energy Savings

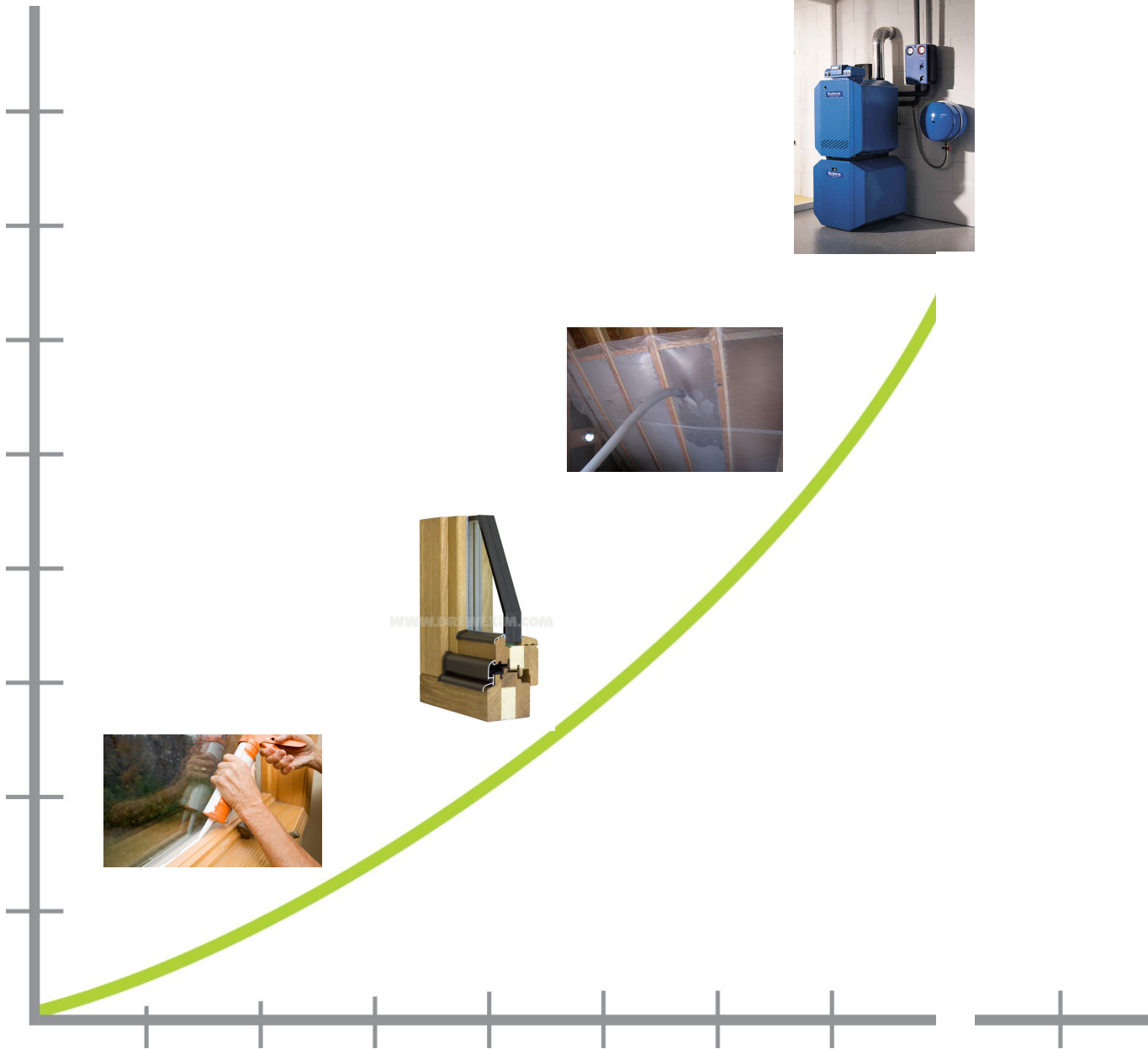

Building Costs

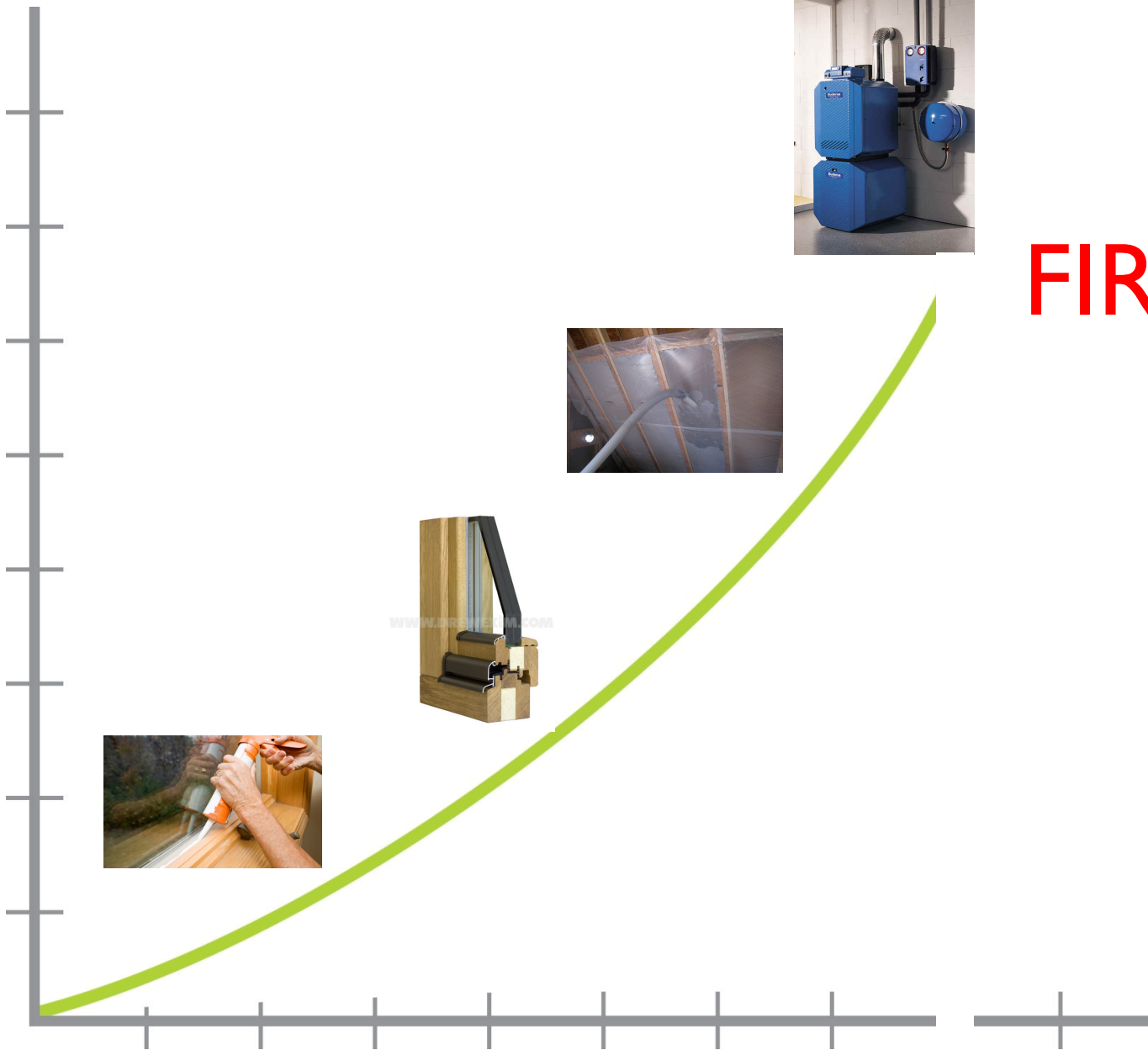

Energy Savings

FIRED!

Building Costs

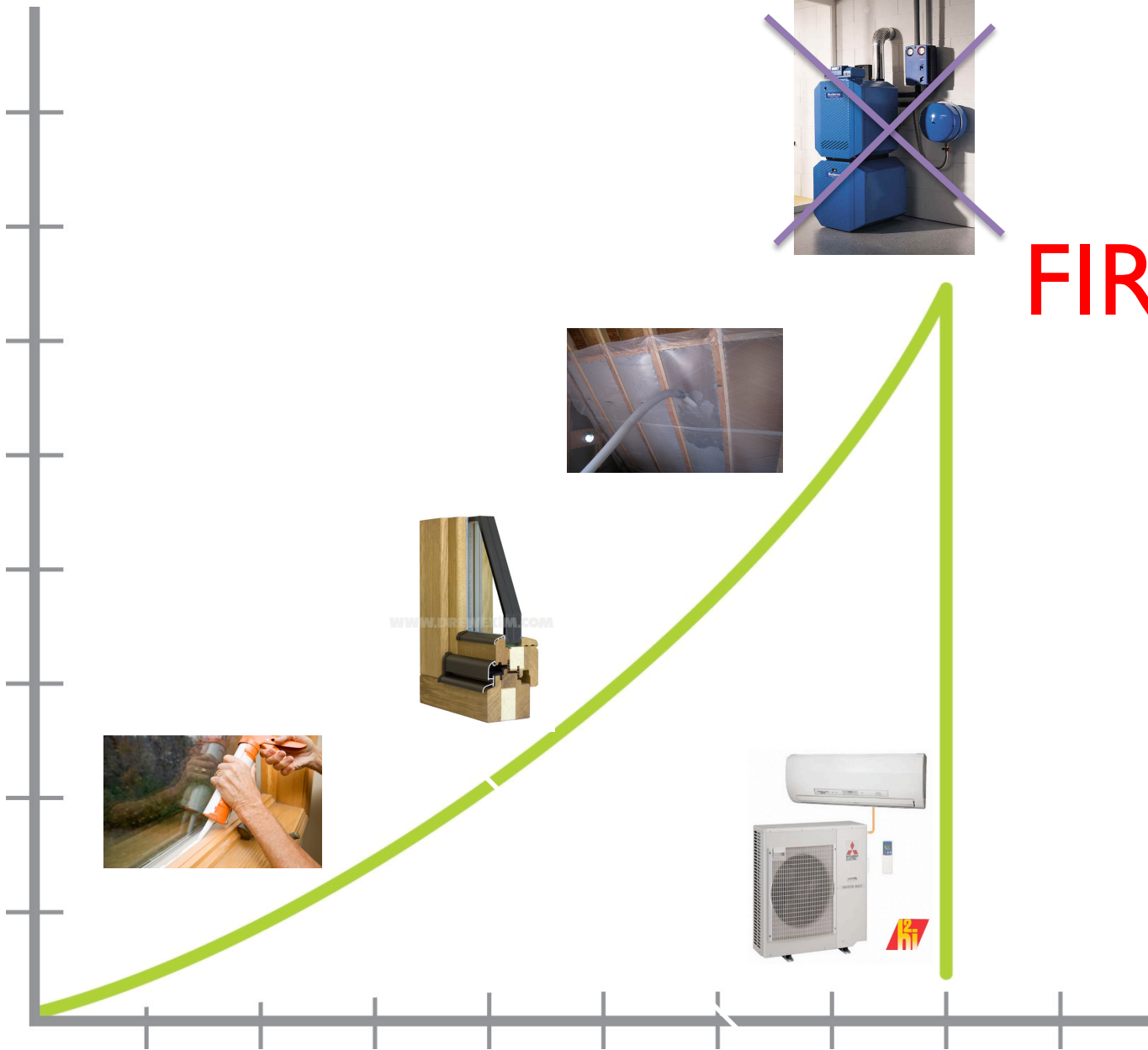

FIRED!

Energy Savings

Building Costs

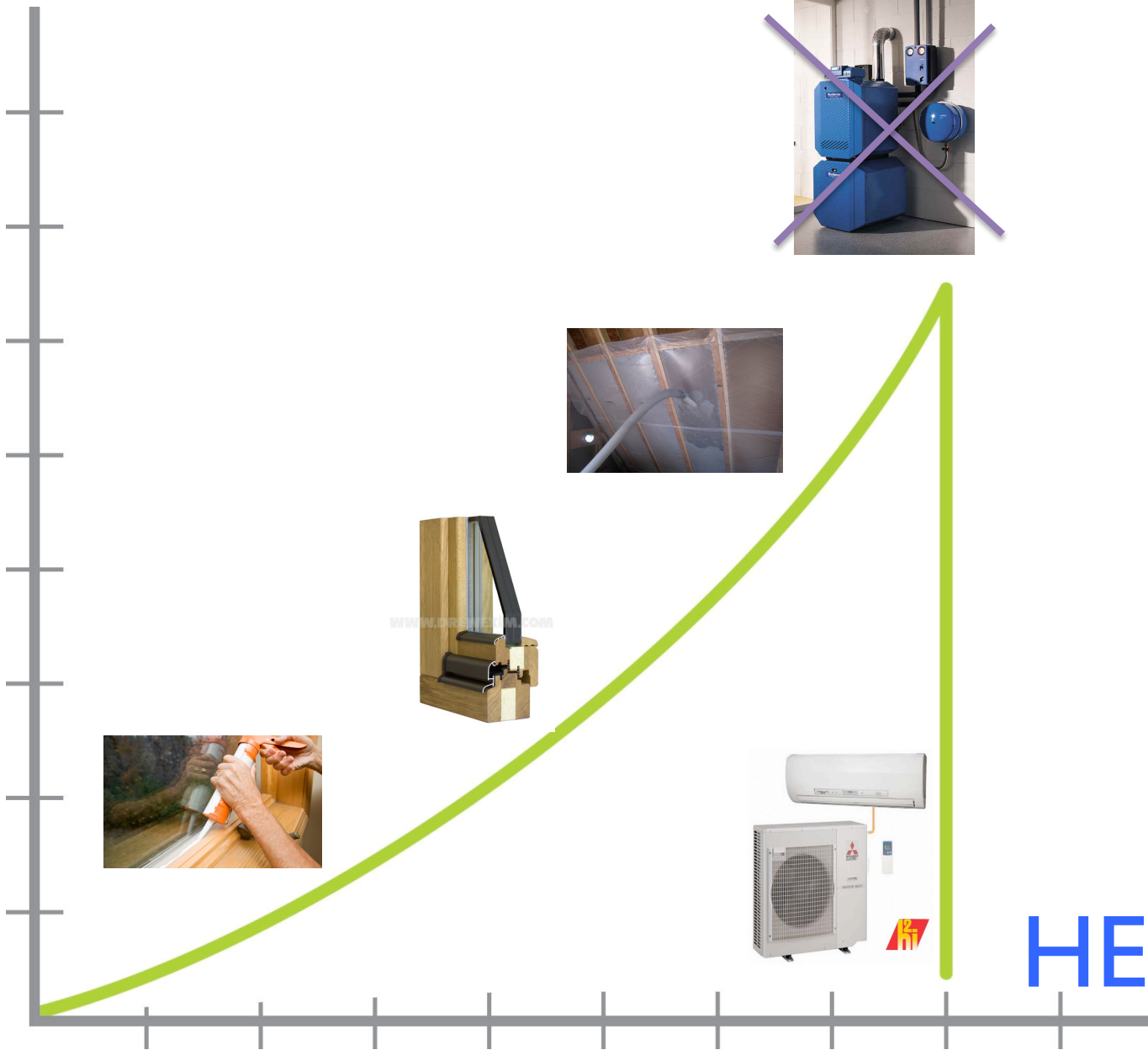

Energy Savings

HERO!



8. Pump it real good

(a.k.a. don't learn mechanical systems from a fossil)

\$9,000 - \$12,000

MINI-SPLIT SYSTEM + BATH FAN

30,000 BTU / HR MAX

- ▶ BATH FAN VENTILATION (\$500)
- ▶ ELECTRIC RESISTANCE HOT WATER (\$1,500)
- ▶ 2 - 3 HEAD WALL-MOUNTED MINI-SPLIT (\$8,000 - \$10,000)



BATH FANS



DHW



HEAT PUMP

PRO	CON
COOLING INCLUDED	EXPENSIVE VENTILATION HEAT LOSSES
MINIMAL PLUMBING	EXPENSIVE HOT WATER COSTS, HIGH SOURCE ENERGY
NO SOURCE ENERGY PENALTY FOR ELECTRIC HEATING	EXPOSED WALL MOUNTED HEATING & COOLING

Saying
“geothermal”
makes you sound
like a dink.

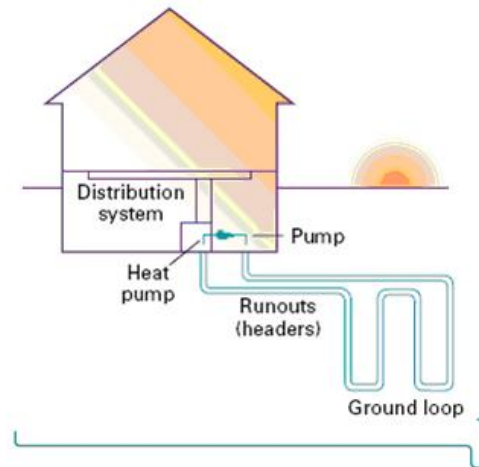



**9. Keep it clean
(a.k.a. tonic, not toxic)**



**“Gee, this looks healthy
to have in my house!”**

Foam softly, and forever hold your tape.

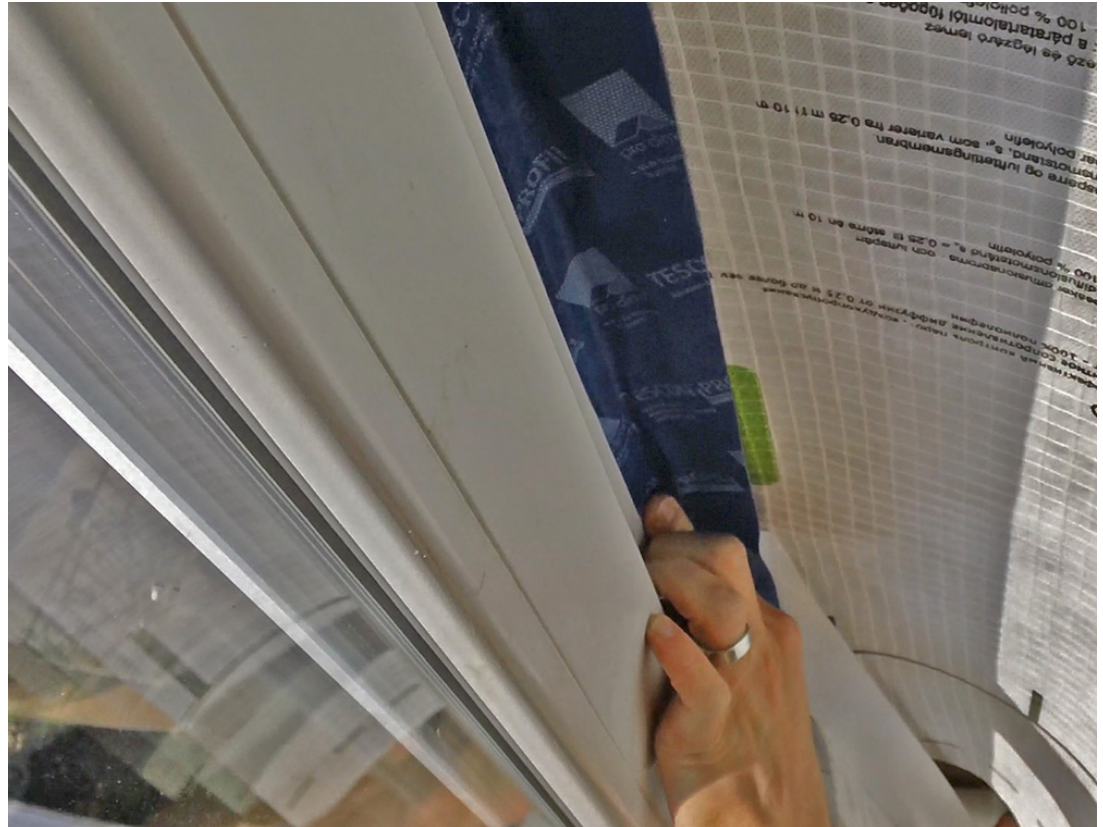

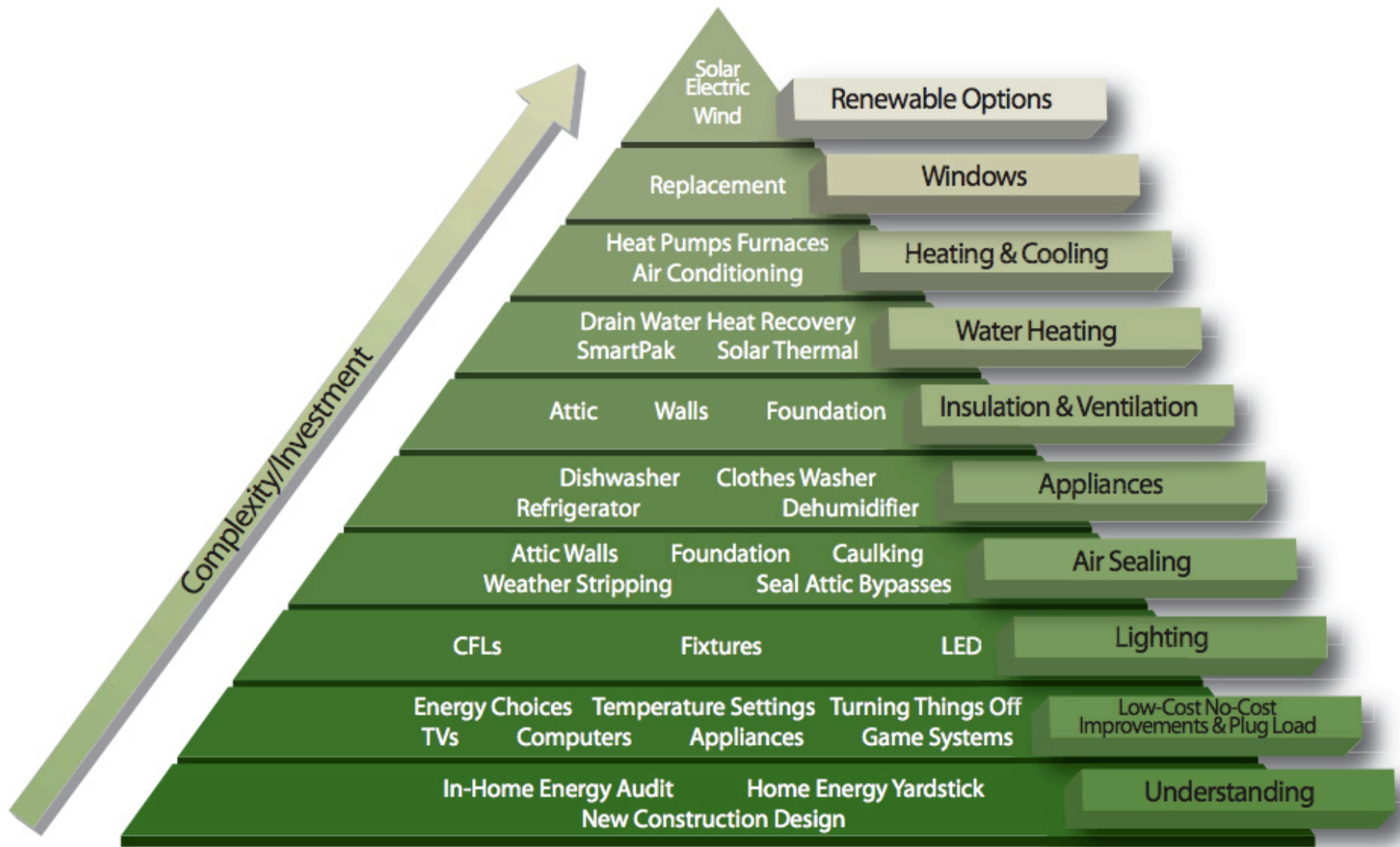

10. Pushing solar first is shady

(a.k.a. grab your low hanging fruit)





11. Blower door me!

$$\text{ACH50} = \frac{(\text{CFM50} \times 60)}{\text{building volume}}$$

What's good?

$$\text{ACH50} = 0.6 - 1.5$$

How do you make this cost effective?



=



12. Touch the sweet spot!

Please send any comments or corrections to: info@kaplanthompson.com		June 24, 2011			
NET-ZERO COST OPTIMIZATION		Kaplan Thompson Architects			
BUILDING DATA		Fixed Cost per month to run your new house 100% on clean, renewable solar energy:			
Utility Electricity cost:	\$0.16	(\$450.59)	(\$202.97)	(\$142.93)	(\$134.58)
kWH Useage / Month:	500				
kWH / yr / kW in this location (from PVwatts):	1,285	Cost per month to run your new house on toxic fossil fuel powered electricity :			
PV Cost / kW (Before Tax Credits):	\$4,500	(\$426.63)	(\$175.73)	(\$114.90)	(\$106.45)
House Model:	Custom	Gap:			
Description:	3BR, 3 story	\$23.96	\$27.23	\$28.03	\$28.14
House Size (square feet):	1,973				
Constr Cost: (\$/SF)	\$175				
Estimated Base House Cost:	\$345,275				
		Option A-1:	Option A-2:	Option B:	Option C:
Window Square Feet: (includes glass doors)	600	CODE MIN (elect base)	CODE MIN (heat pump)	BUILDING SCIENCE	PASSIVHAUS
Exterior Wall Linear Feet:	220	3.0 ACH50	3.0 ACH50	1.5 ACH50	.60 ACH50
Roof Square Feet:	1,580	R-10 Slab	R-10 Slab	R-10 Slab	R-10 Slab
Basement Square Feet:	1,180	R-18 Basement Walls	R-18 Basement Walls	R-20 Basement Walls	R-18 Basement Walls
Slab on Grade Square Feet:	1,180	R-18 Walls	R-18 Walls	R-40 Walls	R-32 Walls
		R-30 Roof	R-30 Roof	R-60 Roof	R-40 Roof
Location:	Rochester, NH	US Double Glazed	US Double Glazed	Canadian Triple Glazed	Canadian Triple Glazed
Peak Heat Load (kBtu / Hour) (system sizing only)		44,000	42,000	18,194	13,824
Annual Heat Load (kBtu / YR)		77,071	75,000	14,653	9,243
Annual Heat Load (kWh/YR)		22,587	21,980	4,294	2,709
kBTU / SF / YR (Passivhaus = 4.75 BTU/sf/yr TFA sfl)		39.06	38.01	7.43	4.68
Heating System Type:		Electric Baseboard	Air Source Heat Pump	Air Source Heat Pump	Air Source Heat Pump
Heating System \$		\$4,400	\$35,000	\$10,000	\$8,000
Ventilation System Cost (exhaust only vs. HRV)		\$500	\$3,000	\$5,000	\$5,000
Heat Pump COP		0.9	3.5	2.5	2.5
Heating Demand (kWh / YR)		25,097	6,280	1,718	1,084
PV Size for Heating (kW)		19.5	4.9	1.3	0.8
PV Cost for Heating (before tax credits)		\$87,888	\$21,993	\$6,015	\$3,795
Lights & Appliances (kWh / YR)		6,000	6,000	6,000	6,000
PV Size for Lights & Apps (kW)		4.7	4.7	4.7	4.7
PV Cost for Lights & Appls (before tax credits)		\$21,012	\$21,012	\$21,012	\$21,012
Family Size		2	2	2	2
DHW demand (kWh / YR)		3,000	3,000	3,000	3,000
Percent of DHW from Solar:		70%	70%	70%	70%
Solar Thermal Cost (after tax credit):		\$5,500	\$5,500	\$5,500	\$5,500
DHW remainder from PV:		900	900	900	900
PV Size for Domestic HW (kW)		0.7	0.7	0.7	0.7
PV Cost for Domestic HW (\$)		\$3,152	\$3,152	\$3,152	\$3,152
Total kWh / Year:		31,997	13,180	8,618	7,984
Total PV Size (kW)		24.9	10.3	6.7	6.2
Total PV Cost (before tax credits)		\$112,052	\$46,156	\$30,179	\$27,958
Total PV Cost After Tax Credits (-30%)		\$78,436	\$32,309	\$21,125	\$19,571
Base House Cost:		\$345,275	\$345,275	\$345,275	\$345,275
Mechanical System Cost:		\$4,900	\$38,000	\$15,000	\$13,000
Construction Cost Increase for Options:		\$0	\$0	\$22,840	\$20,070
Total House Cost:		\$350,175	\$383,275	\$383,115	\$378,345
Total Renewables Cost:		\$83,936	\$37,809	\$26,625	\$25,071
Total Building Cost:		\$434,111	\$421,084	\$409,740	\$403,416
Cost Savings:			\$13,027	\$24,371	\$30,696
Monthly Payment for NET-ZERO Building:	Interest Rate 5.0% Years 30	(\$2,330.40)	(\$2,260.47)	(\$2,199.57)	(\$2,165.62)
Cost Savings per Month:			\$70	\$131	\$165
Renewables Only:					
Cost to Borrow for Solar Systems per Month	5.0% 30	(450.59)	(202.97)	(142.93)	(134.58)
Cost for power from Utility Company (\$0.16 / kWh w/out inflation)		(426.63)	(175.73)	(114.90)	(106.45)
NET-ZERO Difference:		\$24	\$27	\$28	\$28
Standard Building / Month Total Cost:		(\$2,334.44)	(\$2,261.24)	(\$2,199.55)	(\$2,165.49)
Net-Zero Building / Month Total Cost:		(\$2,330.40)	(\$2,260.47)	(\$2,199.57)	(\$2,165.62)
Cost Difference:		(\$4.04)	(\$0.77)	\$0.03	\$0.14

Please send any comments or corrections to: info@kaplanthompson.com

NET-ZERO COST OPTIMIZATION

BUILDING DATA

Utility Electricity cost:	\$0.16
kWH Useage / Month:	500
kWH / yr / kW in this location (from PVwatts):	1,285
PV Cost / kW (Before Tax Credits):	\$4,500
House Model:	Custom
Description:	3BR, 3 story
House Size (square feet):	1,973
Constr Cost: (\$/SF)	\$175
Estimated Base House Cost:	\$345,275
Window Square Feet: (includes glass doors)	600
Exterior Wall Linear Feet:	220
Roof Square Feet:	1,580
Basement Square Feet:	1,180
Slab on Grade Square Feet:	1,180
Location:	Rochester, NH

Fixed Cost per month to run your new house 100% on clean, renewable solar energy:

	(\$450.59)	(\$202.97)	(\$142.93)	(\$100.00)
--	-------------------	-------------------	-------------------	-------------------

Cost per month to run your new house on toxic fossil fuel powered electricity :

	(\$426.63)	(\$175.73)	(\$114.90)	(\$80.00)
--	-------------------	-------------------	-------------------	------------------

Gap:

	\$23.96	\$27.23	\$28.03	\$28.03
--	---------	---------	---------	---------

	Option A-1:	Option A-2:	Option B:	Option C:
	CODE MIN (elect base)	CODE MIN (heat pump)	BUILDING SCIENCE	PASSIVHAUS
	3.0 ACH50	3.0 ACH50	1.5 ACH50	.60 ACH50
	R-10 Slab	R-10 Slab	R-10 Slab	R-10 Slab
	R-18 Basement Walls	R-18 Basement Walls	R-20 Basement Walls	R-18 Basement Walls
	R-18 Walls	R-18 Walls	R-40 Walls	R-32 Walls
	R-30 Roof	R-30 Roof	R-60 Roof	R-40 Roof
	US Double Glazed	US Double Glazed	Canadian Triple Glazed	Canadian Triple Glazed

Peak Heat Load (kBTU / Hour) (system sizing only)	44,000	42,000	18,194	
Annual Heat Load (kBTU / YR)	77,071	75,000	14,653	
Annual Heat Load (kWH/YR)	22,587	21,980	4,294	
kBTU / SF / YR (Passivhaus = 4.75 BTU/sf/yr TFA sf!)	39.06	38.01	7.43	

Heating System Type:

	Electric Baseboard	Ground Source Heat Pump	Air Source Heat Pump	Air Source Heat Pump
Heating System \$	\$4,400	\$35,000	\$10,000	
Ventilation System Cost (exhaust only vs. HRV)	\$500	\$3,000	\$5,000	
Heat Pump COP	0.9	3.5	2.5	
Heating Demand (kWH / YR)	25,097	6,280	1,718	
PV Size for Heating (kW)	19.5	4.9	1.3	
PV Cost for Heating (before tax credits)	\$87,888	\$21,993	\$6,015	

Lights & Appliances (kWH / YR)	6,000	6,000	6,000	
PV Size for Lights & Apps (kW)	4.7	4.7	4.7	
PV Cost for Lights & Applis (before tax credits)	\$21,012	\$21,012	\$21,012	

Family Size	2	2	2	
DHW demand (kWH / YR)	3,000	3,000	3,000	
Percent of DHW from Solar:	70%	70%	70%	
Solar Thermal Cost (after tax credit):	\$5,500	\$5,500	\$5,500	
DHW remainder from PV:	900	900	900	
PV Size for Domestic HW (kW)	0.7	0.7	0.7	
PV Cost for Domestic HW (\$)	\$3,152	\$3,152	\$3,152	

Total kWH / Year:	31,997	13,180	8,618	
Total PV Size (kW)	24.9	10.3	6.7	
Total PV Cost (before tax credits)	\$112,052	\$46,156	\$30,179	

LOCATION		Kaplan Thompson Architects			
		Fixed Cost per month to run your new house 100% on clean, renewable solar energy:			
	\$0.16	(\$450.59)	(\$202.97)	(\$142.93)	(\$134.58)
	500				
		Cost per month to run your new house on toxic fossil fuel powered electricity :			
		(\$426.63)	(\$175.73)	(\$114.90)	(\$106.45)
		Gap:			
	Custom	\$23.96	\$27.23	\$28.03	\$28.14
	3BR, 3 story				
	1,973				
	\$175				
	\$345,275				
		Option A-1:	Option A-2:	Option B:	Option C:
		CODE MIN (elect base)	CODE MIN (heat pump)	BUILDING SCIENCE	PASSIVHAUS
	600	3.0 ACH50	3.0 ACH50	1.5 ACH50	.60 ACH50
	220	R-10 Slab	R-10 Slab	R-10 Slab	R-10 Slab
	1,580	R-18 Basement Walls	R-18 Basement Walls	R-20 Basement Walls	R-18 Basement Walls
	1,180	R-18 Walls	R-18 Walls	R-40 Walls	R-32 Walls
	1,180	R-30 Roof	R-30 Roof	R-60 Roof	R-40 Roof
	Rochester, NH	US Double Glazed	US Double Glazed	Canadian Triple Glazed	Canadian Triple Glazed
		44,000	42,000	18,194	13,824
		77,071	75,000	14,653	9,243
		22,587	21,980	4,294	2,709
		39.06	38.01	7.43	4.68
		Electric Baseboard	Ground Source Heat Pump	Air Source Heat Pump	Air Source Heat Pump
		\$4,400	\$35,000	\$10,000	\$8,000
		\$500	\$3,000	\$5,000	\$5,000
		0.9	3.5	2.5	2.5
		25,097	6,280	1,718	1,084
		19.5	4.9	1.3	0.8
		\$87,888	\$21,993	\$6,015	\$3,795
		6,000	6,000	6,000	6,000
		4.7	4.7	4.7	4.7
		\$21,012	\$21,012	\$21,012	\$21,012
		2	2	2	2
		3,000	3,000	3,000	3,000
		70%	70%	70%	70%
		\$5,500	\$5,500	\$5,500	\$5,500
		900	900	900	900
		0.7	0.7	0.7	0.7
		\$3,152	\$3,152	\$3,152	\$3,152
		31,997	13,180	8,618	7,984
		24.9	10.3	6.7	6.2
		\$112,052	\$46,156	\$30,179	\$27,958
		\$78,436	\$32,309	\$21,125	\$19,571

Heating System Type:			Electric Baseboard	Ground Source Heat Pump	Air Source Heat Pump	Air Source Heat Pump
Heating System \$			\$4,400	\$35,000	\$10,000	\$8,000
Ventilation System Cost (exhaust only vs. HRV)			\$500	\$3,000	\$5,000	\$5,000
Heat Pump COP			0.9	3.5	2.5	2.5
Heating Demand (kWH / YR)			25,097	6,280	1,718	1,084
PV Size for Heating (kW)			19.5	4.9	1.3	0.8
PV Cost for Heating (before tax credits)			\$87,888	\$21,993	\$6,015	\$3,795
Lights & Appliances (kWH / YR)			6,000	6,000	6,000	6,000
PV Size for Lights & Apps (kW)			4.7	4.7	4.7	4.7
PV Cost for Lights & Appls (before tax credits)			\$21,012	\$21,012	\$21,012	\$21,012
Family Size			2	2	2	2
DHW demand (kWH / YR)			3,000	3,000	3,000	3,000
Percent of DHW from Solar:			70%	70%	70%	70%
Solar Thermal Cost (after tax credit):			\$5,500	\$5,500	\$5,500	\$5,500
DHW remainder from PV:			900	900	900	900
PV Size for Domestic HW (kW)			0.7	0.7	0.7	0.7
PV Cost for Domestic HW (\$)			\$3,152	\$3,152	\$3,152	\$3,152
Total kWH / Year:			31,997	13,180	8,618	7,984
Total PV Size (kW)			24.9	10.3	6.7	6.2
Total PV Cost (before tax credits)			\$112,052	\$46,156	\$30,179	\$27,958
Total PV Cost After Tax Credits (-30%)			\$78,436	\$32,309	\$21,125	\$19,571
Base House Cost:			\$345,275	\$345,275	\$345,275	\$345,275
Mechanical System Cost:			\$4,900	\$38,000	\$15,000	\$13,000
Construction Cost Increase for Options:			\$0	\$0	\$22,840	\$20,070
Total House Cost:			\$350,175	\$383,275	\$383,115	\$378,345
Total Renewables Cost:			\$83,936	\$37,809	\$26,625	\$25,071
Total Building Cost:			\$434,111	\$421,084	\$409,740	\$403,416
Cost Savings:				\$13,027	\$24,371	\$30,696
	Interest Rate	Years				
Monthly Payment for NET-ZERO Building:	5.0%	30	(\$2,330.40)	(\$2,260.47)	(\$2,199.57)	(\$2,165.62)
Cost Savings per Month:				\$70	\$131	\$165
Renewables Only:						
Cost to Borrow for Solar Systems per Month	5.0%	30	(450.59)	(202.97)	(142.93)	(134.58)
Cost for power from Utility Company (\$0.16 / kWh w/out inflation)			(426.63)	(175.73)	(114.90)	(106.45)
NET-ZERO Difference:			\$24	\$27	\$28	\$28
Standard Building / Month Total Cost:			(\$2,334.44)	(\$2,261.24)	(\$2,199.55)	(\$2,165.49)
Net-Zero Building / Month Total Cost:			(\$2,330.40)	(\$2,260.47)	(\$2,199.57)	(\$2,165.62)
Cost Difference:			(\$4.04)	(\$0.77)	\$0.03	\$0.14



**13. Sustainability is
design, dummy.**





F+ = FAIL!



**14. Don't LEED your clients
down a dark alley.**

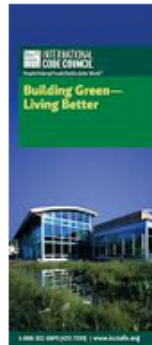

15. Watch your language!

QUALITY
DURABILITY
COMFORT
SECURITY
INVESTMENT



NESEA™

NORTHEAST SUSTAINABLE ENERGY ASSOCIATION



Passive House Institute US



Green Building Advisor.com

The Complete Source for Building, Designing and Remodeling Green Homes



BuildingGreen.com

15. Watch your language!



15. Watch your language!

14. Don't LEED your clients down a dark alley.



15. Watch your language!
14. Don't LEED your clients down a dark alley.
13. Sustainability is design, dummy.



15. Watch your language!
14. Don't LEED your clients down a dark alley.
13. Sustainability is design, dummy.
12. Touch the sweet spot!



15. Watch your language!
14. Don't LEED your clients down a dark alley.
13. Sustainability is design, dummy.
12. Touch the sweet spot!
11. Blower door me!



15. Watch your language!
14. Don't LEED your clients down a dark alley.
13. Sustainability is design, dummy.
12. Touch the sweet spot!
11. Blower door me!
10. Pushing solar first is shady

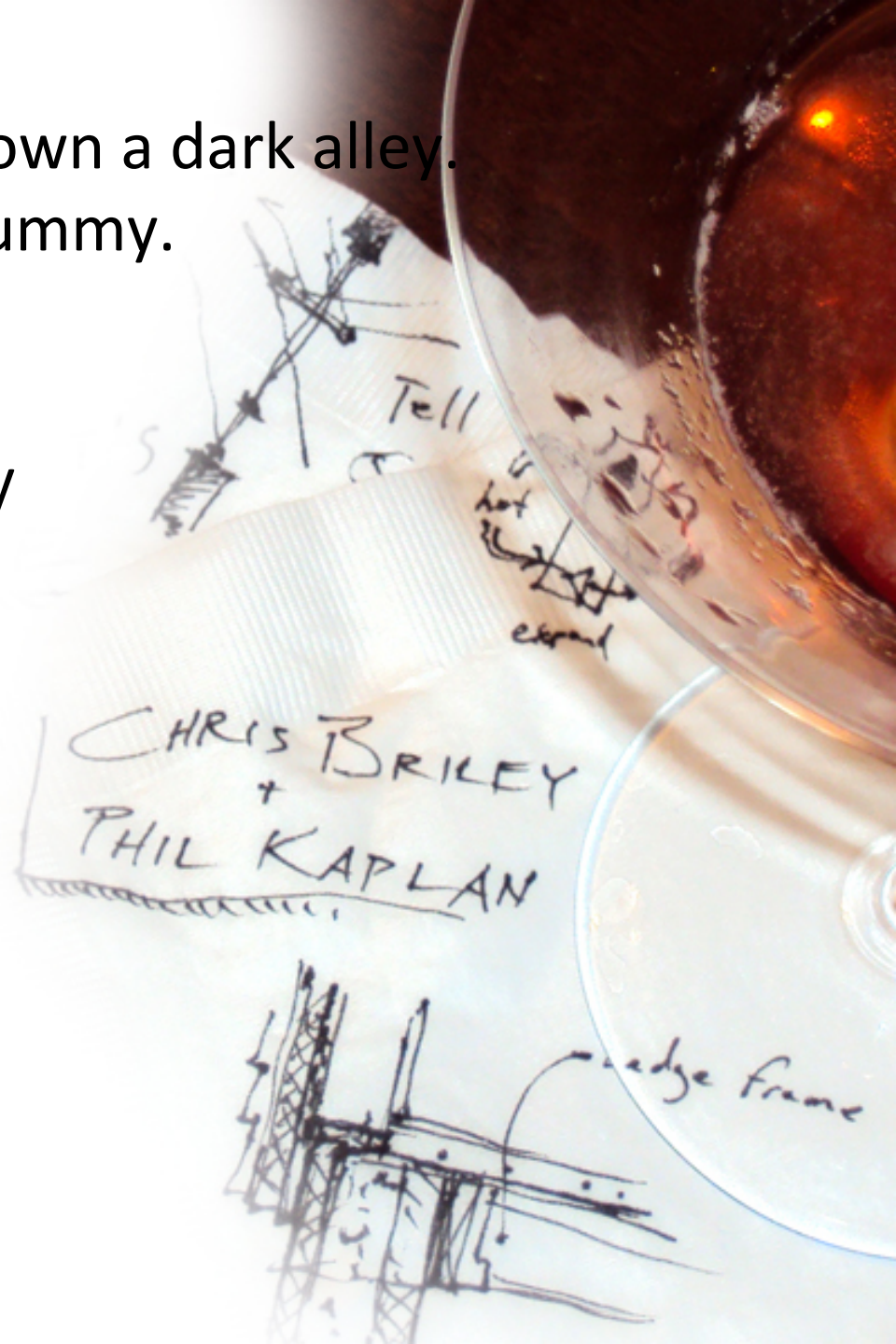

15. Watch your language!
14. Don't LEED your clients down a dark alley.
13. Sustainability is design, dummy.
12. Touch the sweet spot!
11. Blower door me!
10. Pushing solar first is shady
9. Keep it clean

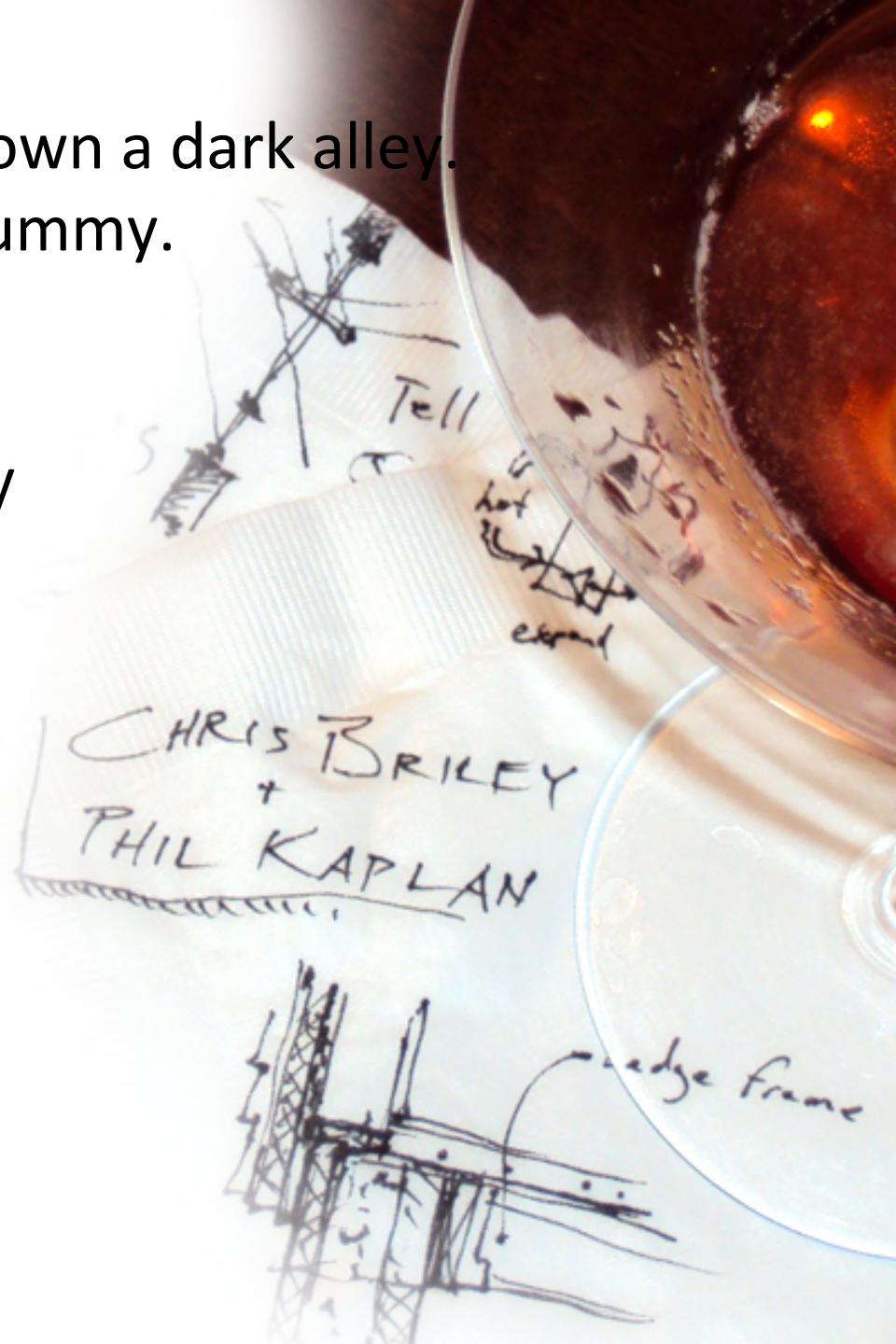

15. Watch your language!
14. Don't LEED your clients down a dark alley.
13. Sustainability is design, dummy.
12. Touch the sweet spot!
11. Blower door me!
10. Pushing solar first is shady
9. Keep it clean
8. Pump it real good

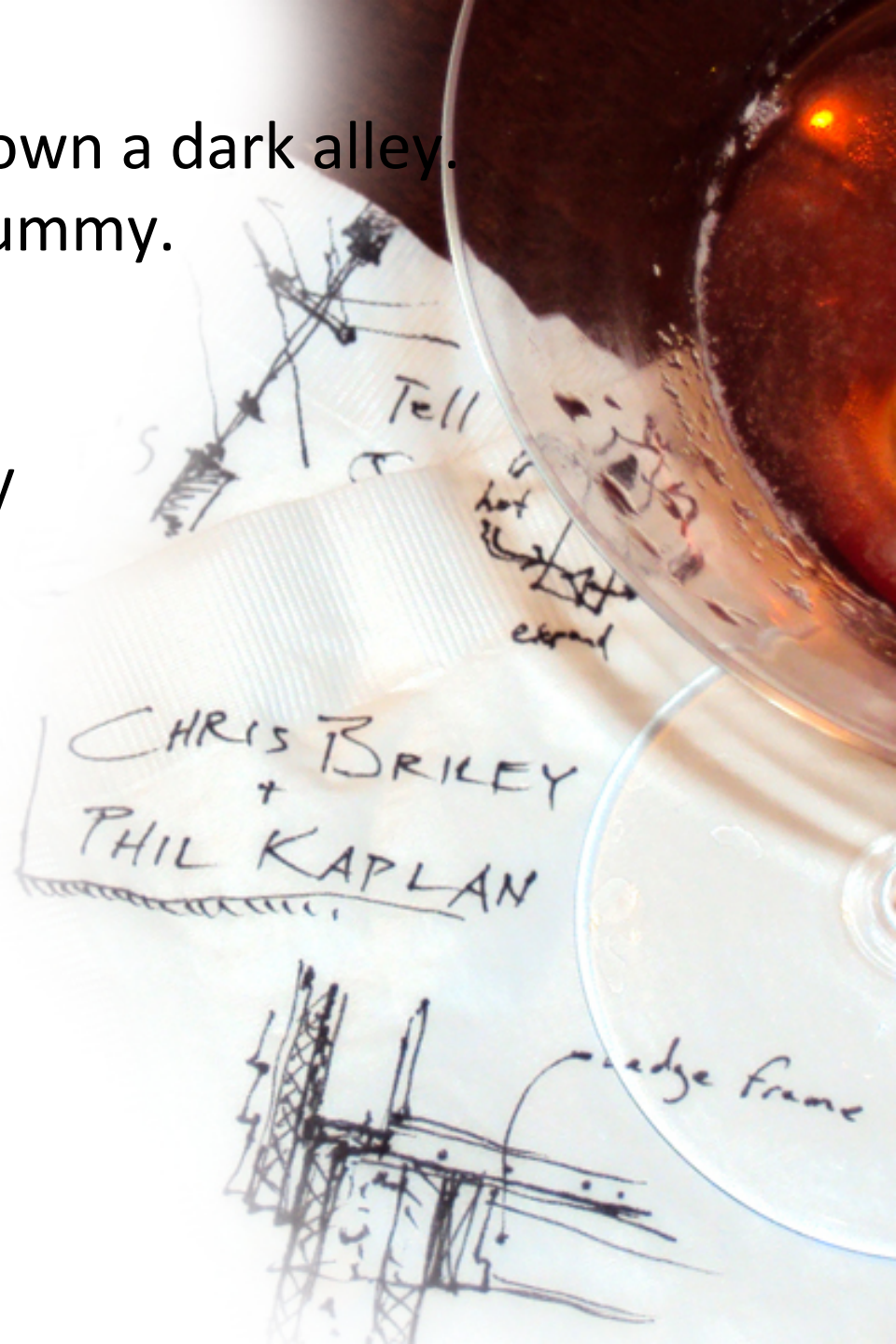

CHRIS BRILEY
+
PHIL KAPLAN

15. Watch your language!
14. Don't LEED your clients down a dark alley.
13. Sustainability is design, dummy.
12. Touch the sweet spot!
11. Blower door me!
10. Pushing solar first is shady
9. Keep it clean
8. Pump it real good
7. Bigger isn't better

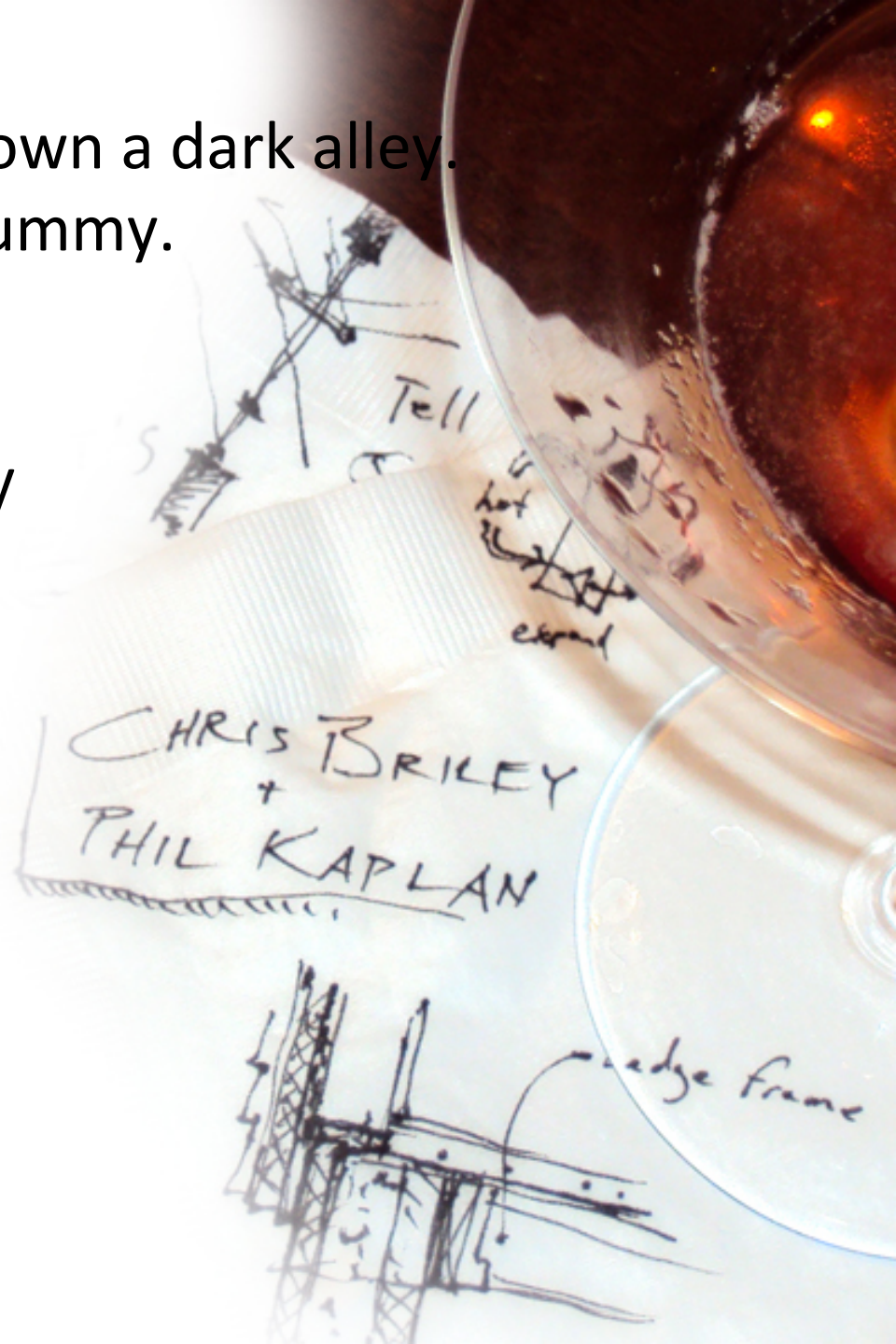

15. Watch your language!
14. Don't LEED your clients down a dark alley.
13. Sustainability is design, dummy.
12. Touch the sweet spot!
11. Blower door me!
10. Pushing solar first is shady
9. Keep it clean
8. Pump it real good
7. Bigger isn't better
6. Do your modeling before the runway

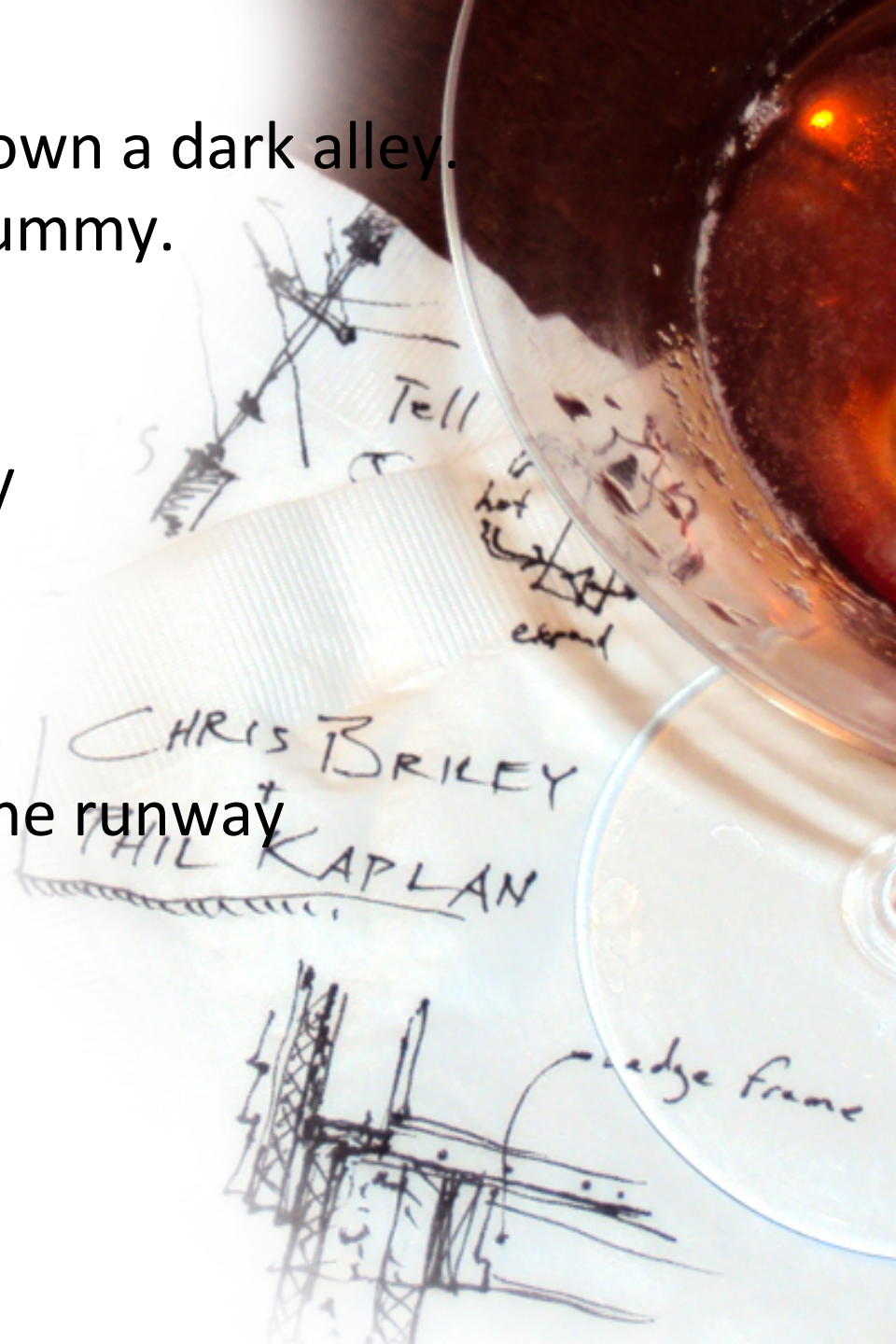

15. Watch your language!
14. Don't LEED your clients down a dark alley.
13. Sustainability is design, dummy.
12. Touch the sweet spot!
11. Blower door me!
10. Pushing solar first is shady
9. Keep it clean
8. Pump it real good
7. Bigger isn't better
6. Do your modeling before the runway
5. Don't wait to integrate

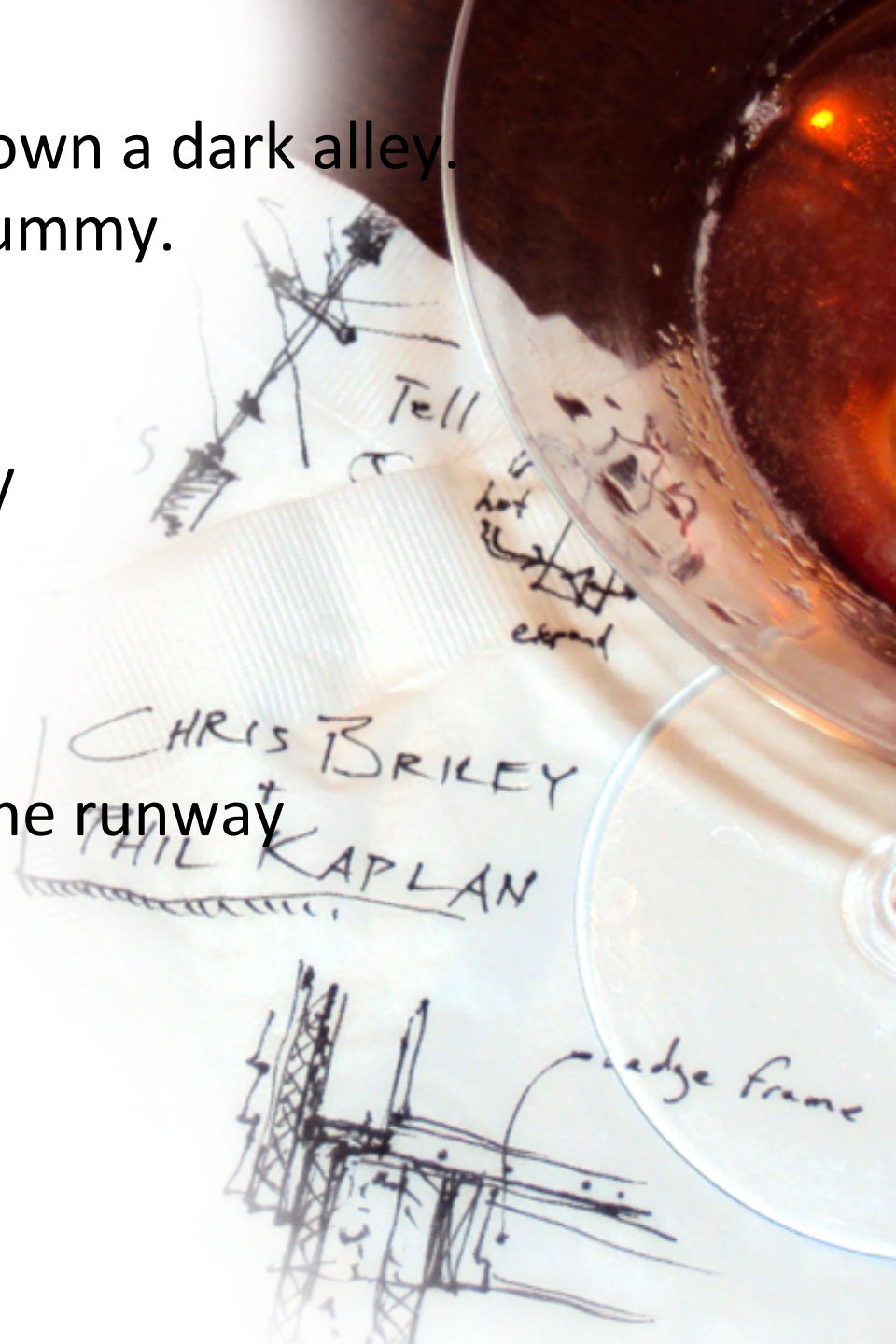

15. Watch your language!
14. Don't LEED your clients down a dark alley.
13. Sustainability is design, dummy.
12. Touch the sweet spot!
11. Blower door me!
10. Pushing solar first is shady
9. Keep it clean
8. Pump it real good
7. Bigger isn't better
6. Do your modeling before the runway
5. Don't wait to integrate
4. Belt, suspenders and clean underwear

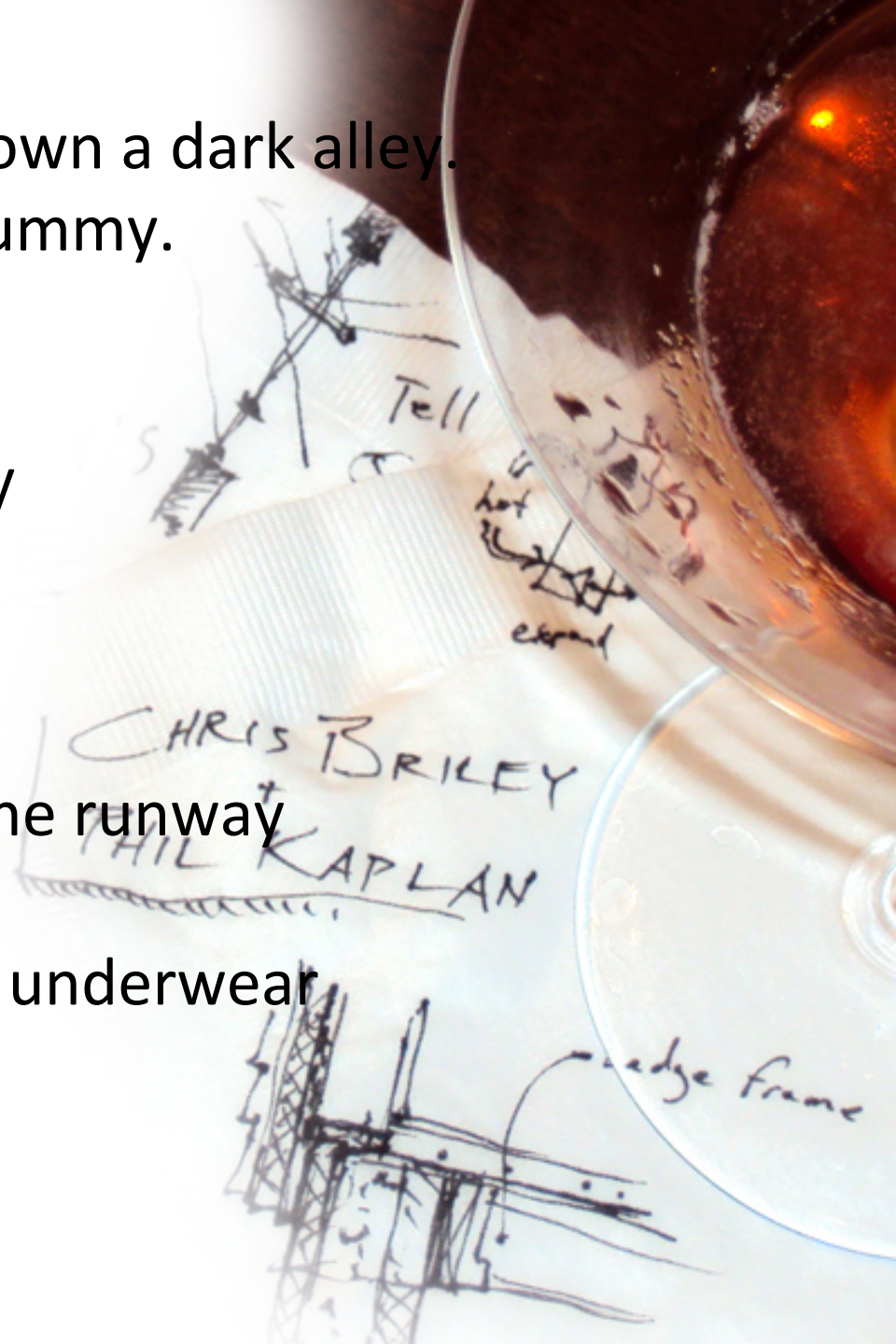

15. Watch your language!
14. Don't LEED your clients down a dark alley.
13. Sustainability is design, dummy.
12. Touch the sweet spot!
11. Blower door me!
10. Pushing solar first is shady
9. Keep it clean
8. Pump it real good
7. Bigger isn't better
6. Do your modeling before the runway
5. Don't wait to integrate
4. Belt, suspenders and clean underwear
3. Don't cross that bridge when you come to it

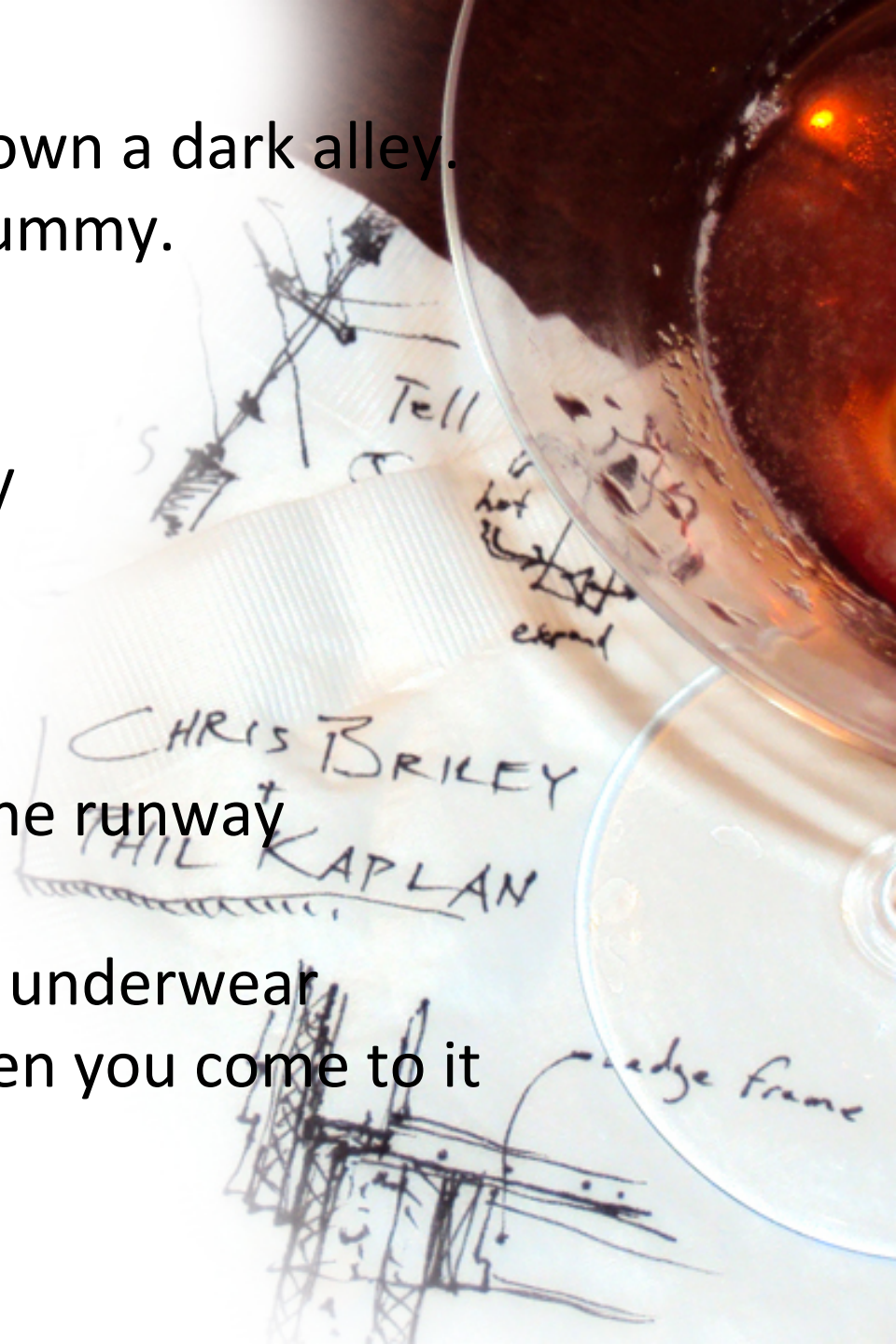

15. Watch your language!
14. Don't LEED your clients down a dark alley.
13. Sustainability is design, dummy.
12. Touch the sweet spot!
11. Blower door me!
10. Pushing solar first is shady
9. Keep it clean
8. Pump it real good
7. Bigger isn't better
6. Do your modeling before the runway
5. Don't wait to integrate
4. Belt, suspenders and clean underwear
3. Don't cross that bridge when you come to it
2. Raise your glass

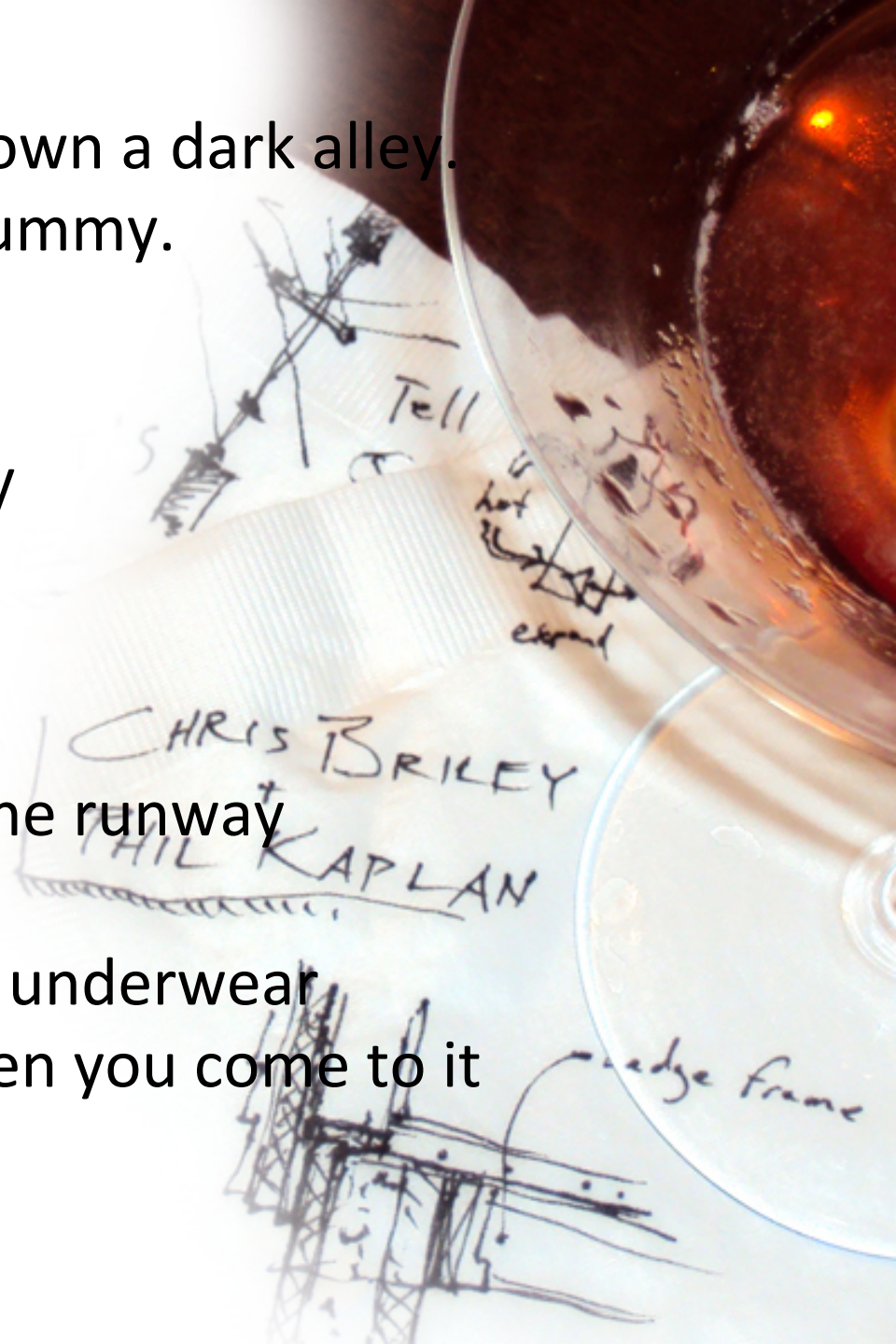

15. Watch your language!
14. Don't LEED your clients down a dark alley.
13. Sustainability is design, dummy.
12. Touch the sweet spot!
11. Blower door me!
10. Pushing solar first is shady
9. Keep it clean
8. Pump it real good
7. Bigger isn't better
6. Do your modeling before the runway
5. Don't wait to integrate
4. Belt, suspenders and clean underwear
3. Don't cross that bridge when you come to it
2. Raise your glass
1. Don't be an Airhole!

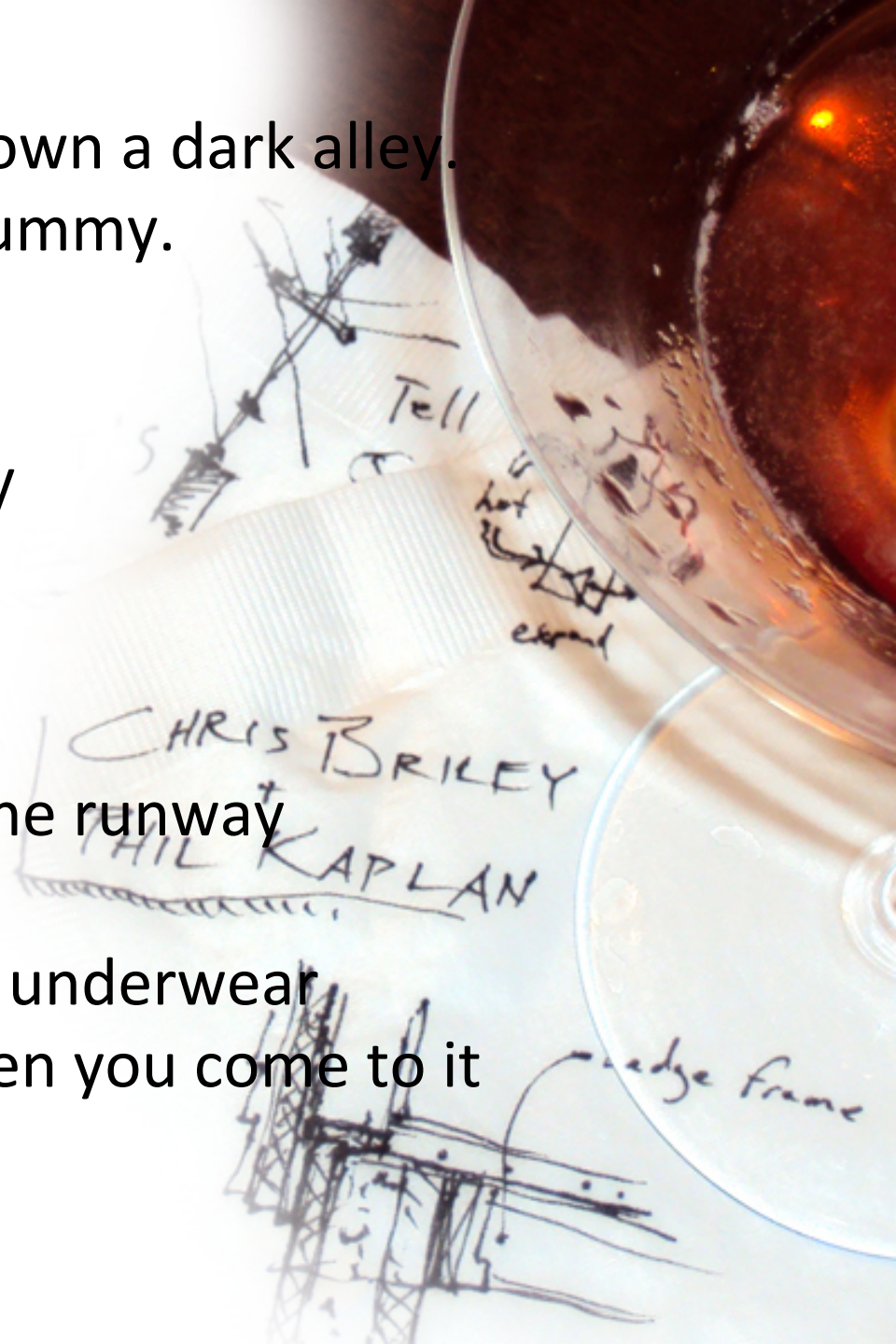

CHEERS!





CHRISTOPHER BRILEY, RA, LEED BD+C
BRIBURN
28 MAPLE ST. PORTLAND, MAINE
207-774-8482 www.architectureforlife.com
cbriley@briburn.com



PHIL KAPLAN, AIA, LEED AP
KAPLAN THOMPSON ARCHITECTS
424 FORE ST. PORTLAND, MAINE
207-842-8888 www.kaplanthompson.com
phil@kaplanthompson.com